

Where is the math?

Dag Wedelin
Datavetenskap
Chalmers

lunch talk December 2015-16

Where is the math?

Matematisk modellering kan sägas vara länken mellan matematiken och verkligheten, där man ofta behöver arbeta kreativt för att hitta användbara förenklingar. I detta lunchföredrag vill jag ge lite personliga exempel, bland annat från mitt eget arbete med optimering för flygbolag. Jag vill också illustrera hur matematiskt tänkande, inklusive den viktiga förmågan att se saker på ett matematiskt sätt, hänger ihop med mycket av vad vi gör inom datavetenskapen. Jag vill även förutom den kurs i matematisk modellering och problemlösning som jag själv ger i tvåan, kort beskriva inriktningar inom utbildningen där datavetenskap och matematik går hand i hand, och hur detta i högsta grad ligger i tiden.

If you want to do things
with computers...

**You need
programming!**

```
import java.awt.*;

public abstract class Animation
    extends java.applet.Applet
    implements java.lang.Runnable {

    protected Dimension d; // bitmap size
    protected Image im; // extra image for drawing
    protected Graphics offscreen; // the offscreen bitmap to draw in
    protected int delay = 100; // in milliseconds
    protected Thread animationThread;

    final public void init() {
        d = getSize();
        im = createImage(d.width, d.height);
        offscreen = im.getGraphics();
        initAnimator();
    }

    //final public void paint(Graphics g) {update(g);}

    final public void update(Graphics g) {
        paintAnimator(offscreen); // first draw offscreen to reduce flicker
        g.drawImage(im, 0, 0, this); // then put on screen
    }

    // To be implemented in subclass that does the actual drawing
    protected void initAnimator() {} // init for drawing routines
    abstract protected void paintAnimator(Graphics g); // the actual
drawing will be here

    public void setDelay(int d) {delay=d;}

    public void start() {
        animationThread = new Thread(this);
        animationThread.start();
    }

    public void stop() {
```

But if you want to do something more complicated...

You need algorithms!

Nilsson, Sven
Lundberg, Lovisa
Larsson, Erik
Sjöberg, Anna
Carlén, Johanna
Persson, Mikael

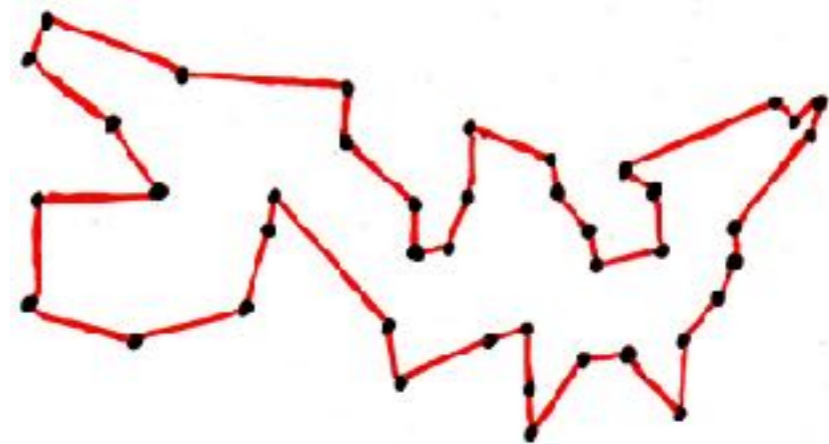

But to use, understand and create algorithms...

You often need math!

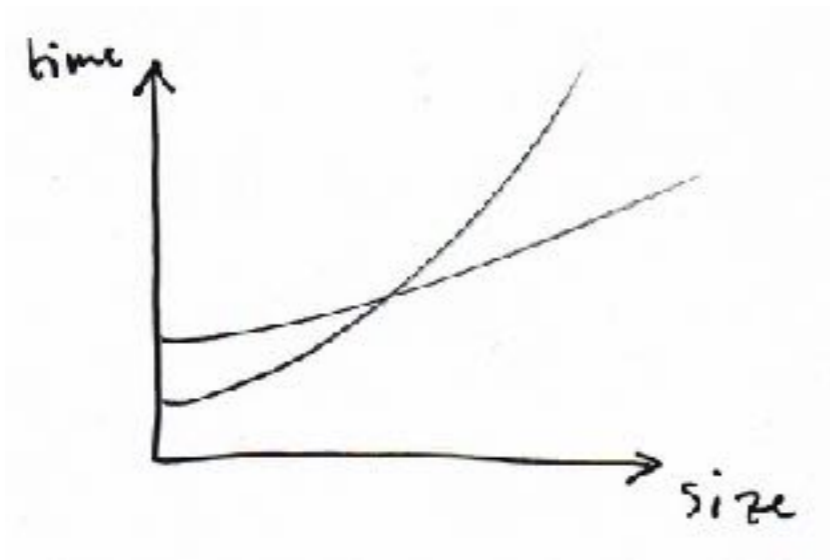

$$\text{minimize } \sum_{ij \in A} w_{ij} x_{ij} \quad \text{subject to } x \geq 0$$

$$\sum_j x_{ij} - \sum_j x_{ji} = \begin{cases} 1, & \text{if } i = s; \\ -1, & \text{if } i = t; \\ 0, & \text{otherwise.} \end{cases}$$





$$\begin{aligned}
 Y' &= 16 + (65.481 \cdot R' + 128.553 \cdot G' + 24.966 \cdot B') \\
 C_B &= 128 + (-37.797 \cdot R' - 74.203 \cdot G' + 112.0 \cdot B') \\
 C_R &= 128 + (112.0 \cdot R' - 93.786 \cdot G' - 18.214 \cdot B')
 \end{aligned}$$

$$G_{u,v} = \sum_{x=0}^7 \sum_{y=0}^7 \alpha(u)\alpha(v)g_{x,y} \cos \left[\frac{\pi}{8} \left(x + \frac{1}{2} \right) u \right] \cos \left[\frac{\pi}{8} \left(y + \frac{1}{2} \right) v \right]$$

The Travelling Salesperson Problem

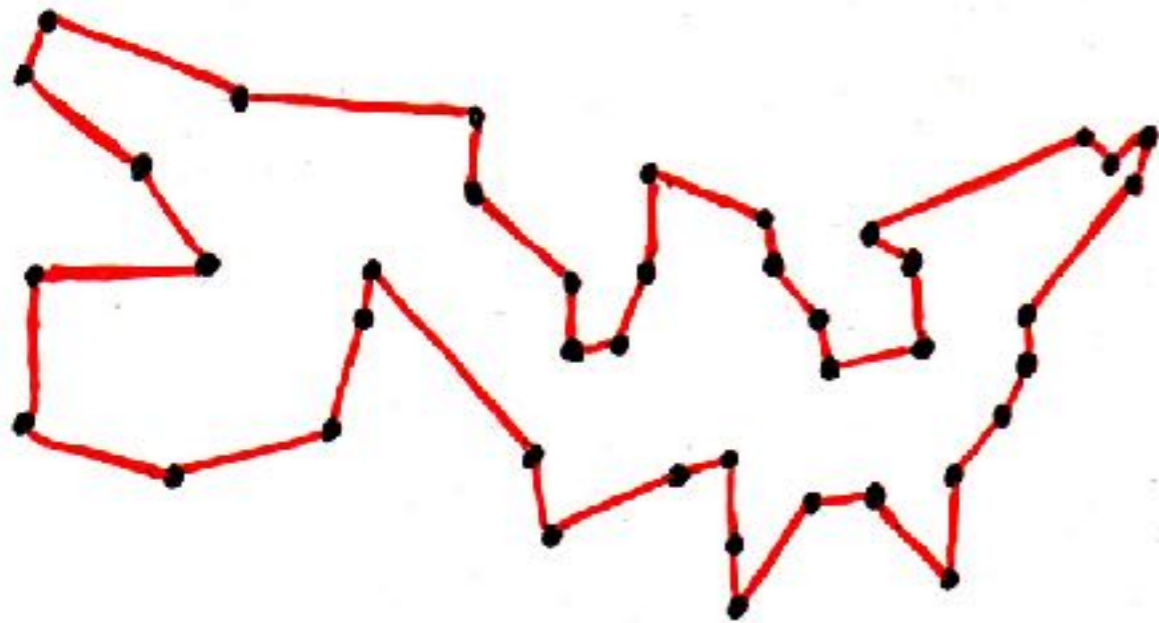

n	$c 2^n$
10	0,001 s
20	1 s
30	18 min
40	13 days
50	36 years
60	36600 years

TSP

Sweden Tour

24,978 Cities

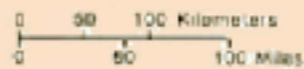

Lambert Conformal Conic Projection, SP 47N02P



The Shortest Path Problem



västtrafik Startida All resa Trafikföretag Priser & Kort Om Västtrafik Adresser Kontakta oss Mina sidor

Resplaneraren

2017-08-04 08:00 (Ållgård) - Östergat. 2017-08-04 08:00 (Ållgård) (Senast 14 minuter sedan)

Ållgård	Ållgård	Ållgård	Ållgård	Tidpunkt
<input type="checkbox"/> 01:00	01:00	01:00	1	Sydväg 8, Sydväg 7
<input checked="" type="checkbox"/> 01:00	01:00	01:00	1	Sydväg 8, Sydväg 7
<input type="checkbox"/> 01:00	01:00	01:00	1	Sydväg 8, Sydväg 7
<input type="checkbox"/> 01:00	01:00	01:00	0	Sydväg 8
<input type="checkbox"/> 01:00	01:00	01:00	1	Sydväg 8, Sydväg 7
<input type="checkbox"/> 01:00	01:00	01:00	1	Sydväg 8, Sydväg 7

Linje	Förlopp	För	Information
Sydväg 8	Sydväg 8, Sydväg 7	08:00 - 08:00	Ållgård, Ållgård
Sydväg 7	Sydväg 7, Sydväg 8	08:00 - 08:00	Ållgård, Ållgård

Skicka till

Om du vill

How solve?

Solving the directed shortest path problem with dynamic programming

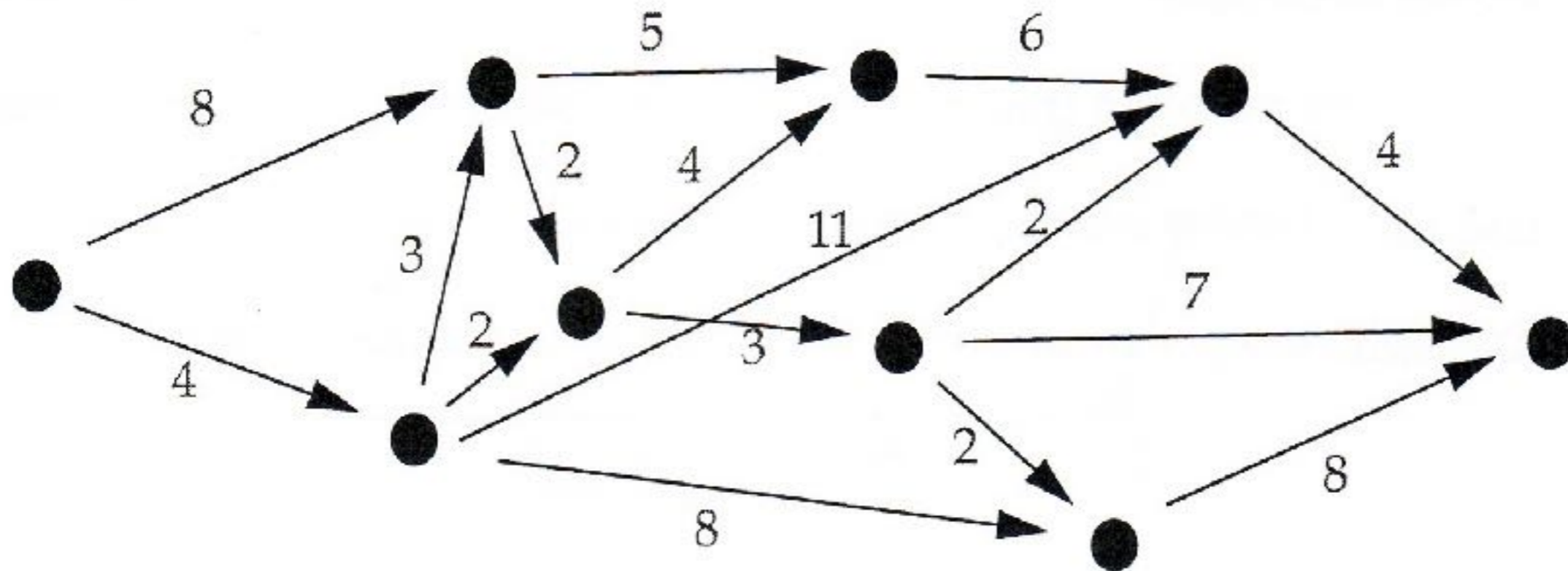

Traverse nodes from left to right and mark with distance from origin.

Circumvents the combinatorial explosion!
(not possible for all kinds of problems)

Text search is mathematical



statistical models and algorithms

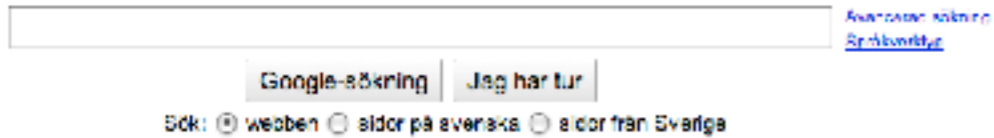

search algorithms

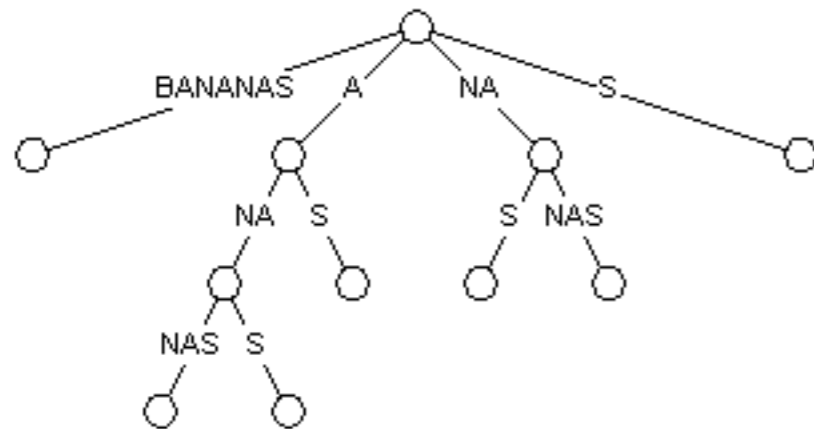

... my urgent need for a foreign partner after going through your profile that made me contact you for business partner Transaction. I am a banker by profession...

$$p(C|F_1, \dots, F_n) = \frac{1}{Z} p(C) \prod_{i=1}^n p(F_i|C)$$

machine learning, pattern recognition

FTFTALILL-AVAV
--FTAL-LLAAV--

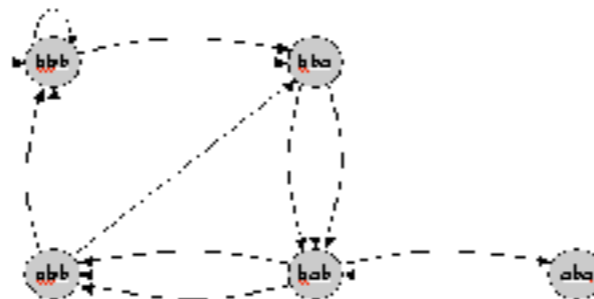

The result of the whole of a conception can be affirmed or denied of the whole of this critique, and obliges us to fall back on the old mode of metaphysical procedure.

Data	Plan	Rule	APC	Report	Options	Help										
Window	01/11	02/11	03/11	04/11	05/11	06/11	07/11	08/11	09/11	10/11	11/11	12/11	13/11	14/11		
	01/11			02/11			03/11			04/11						
1 12 0/0/0/0/1/2	FRA	3 3	3	LIN	LIN	36 325 325	FRA									
1 1 0/0/0/0/1/2	MUC	43 43 40 40	0-0 100	MUC												
1 12345 0/0/0/0/1/2	FRA	40	40 40 40	HAM	HAM	40 40 41 41	HAM	HAM	0	3728	ATH	ATH	373 380	IST		
1 123456 0/0/0/0/1/2	FRA	2	4 4 4 4	DUS	DUS	4 4 4 4	DUS	DUS	4 4 4 4	DUS	DUS	DUS	DUS	DUS		
1 123456 0/0/0/0/1/2	FRA	0	HAJ 40 40	HAJ	HAJ	40 40 41 41	HAJ	HAJ	40 40 41 41	HAJ	HAJ	HAJ	HAJ	HAJ		
1 12 0/0/0/0/1/2	FRA	31 31	3210 3210	SVO	SVO	3213 481 470	FRA									
1 12356 0/0/0/0/1/2	FRA	3210 3210	1005 1005	GVA	GVA	46 4	BRU	BRU	4 36 3	NAP						
1 12 0/0/0/0/1/2	MUC	40 40	3	BUD	BUD	35 38 3	MUC									
1 12345 0/0/0/0/1/2	FRA	3 34	3816 15-15	IST	IST	380 373	ATH	ATH	3723 3846	IST	IST	380 373	ATH			
1 12 0/0/0/0/1/2	FRA	4 4	4	GVA	GVA	46 1000-1530	FRA									
1 12 0/0/0/0/1/2	FRA	4 4	4	CDG	CDG	4 1000-1530	FRA									
1 123 0/0/0/0/1/2	FRA	3 35	4	BRU	BRU	4 2 3 4	BRU	BRU	4 4616 4807	FRA						
1 123456 0/0/0/0/1/2	FRA	3846 3847	0	HAM	HAM	40 40	HAM	HAM	40 40	HAM	HAM	40 40	HAM			
1 1 0/0/0/0/1/2	FRA	4 46	005	FRA												
1 123 0/0/0/0/1/2	FRA	3736	5-0	ATH	ATH	3723 3	LIN	LIN	36 325 325	FRA						
1 1 0/0/0/0/1/2	FRA	4816 4807	10-25 45-10	FRA												
1 123 0/0/0/0/1/2	FRA	3 3	0	HAJ	HAJ	0 28 28 4	GVA	GVA	46 4 4	FRA						
1 1234 0/0/0/0/1/2	FRA	2	3230 3221	DUS	DUS	4 4 4 4	DUS	DUS	3238 1020	SVO	SVO	3213 481 470	FRA			
1 123456 0/0/0/0/1/2	FRA	481 478	0-0 0-0	STR	STR	40 40	STR	STR	40 40	STR	STR	40 40	STR			
1 123456 0/0/0/0/1/2	FRA	33 3	8	DUS	DUS	4 4	DUS	DUS	4 4	DUS	DUS	DUS	DUS			
1 1 0/0/0/0/1/2	FRA	480 475	3 3	FRA												
1 1 0/0/0/0/1/2	FRA	325 325	5-0 5-0	FRA												
1 1 0/0/0/0/1/2	FRA	341 341	4 4	FRA												
1 1 0/0/0/0/1/2	FRA	47 47	48 48	FRA												
1 123 0/0/0/0/1/2	MUC	35	05	NAP	NAP	3 35 4	GVA	GVA	46 3 3	MUC						

Window	01/11	02/11	03/11	04/11	05/11	06/11	07/11	08/11	09/11	10/11	11/11	12/11	13/11	14/11
	01/11	02/11	03/11	04/11	05/11	06/11	07/11	08/11	09/11	10/11	11/11	12/11	13/11	14/11

The resulting optimization problem

$$\begin{aligned} \text{minimize} \quad & 2x_1 + 2x_2 + 2x_3 + 2x_4 + x_5 + x_6 + x_7 + x_8 + 2x_9 + 2x_{10} \\ & + 2x_{11} + 2x_{12} + 2x_{13} + 2x_{14} + 2x_{15} + 2x_{16} + 2x_{17} \end{aligned}$$

subject to

$$x_1 + x_2 + x_3 + x_4 + x_9 + x_{10} = 1$$

$$x_1 + x_2 + x_3 + x_4 + x_9 + x_{10} = 1$$

$$x_2 + x_5 + x_6 + x_8 + x_{11} + x_{12} + x_{13} + x_{14} + x_{15} = 1$$

$$x_2 + x_3 + x_5 + x_8 + x_{11} + x_{13} + 2x_{14} + 2x_{15} + x_{16} + x_{17} = 1$$

$$x_3 + x_4 + x_7 + x_8 + x_{10} + x_{13} + x_{14} + 2x_{15} + x_{16} + 2x_{17} = 1$$

$$x_4 + x_6 + x_7 + x_8 + x_{10} + x_{12} + x_{13} + x_{15} + x_{17} = 1$$

$$x_1, x_2, x_3, x_4, x_5, x_6, x_7, x_8, x_9, x_{10}, x_{11}, x_{12}, x_{13}, x_{14}, x_{15}, x_{16}, x_{17} \in \{0, 1\}$$

PAROS

A “dual” algorithm

Minimize piecewise linear convex function with coordinate descent

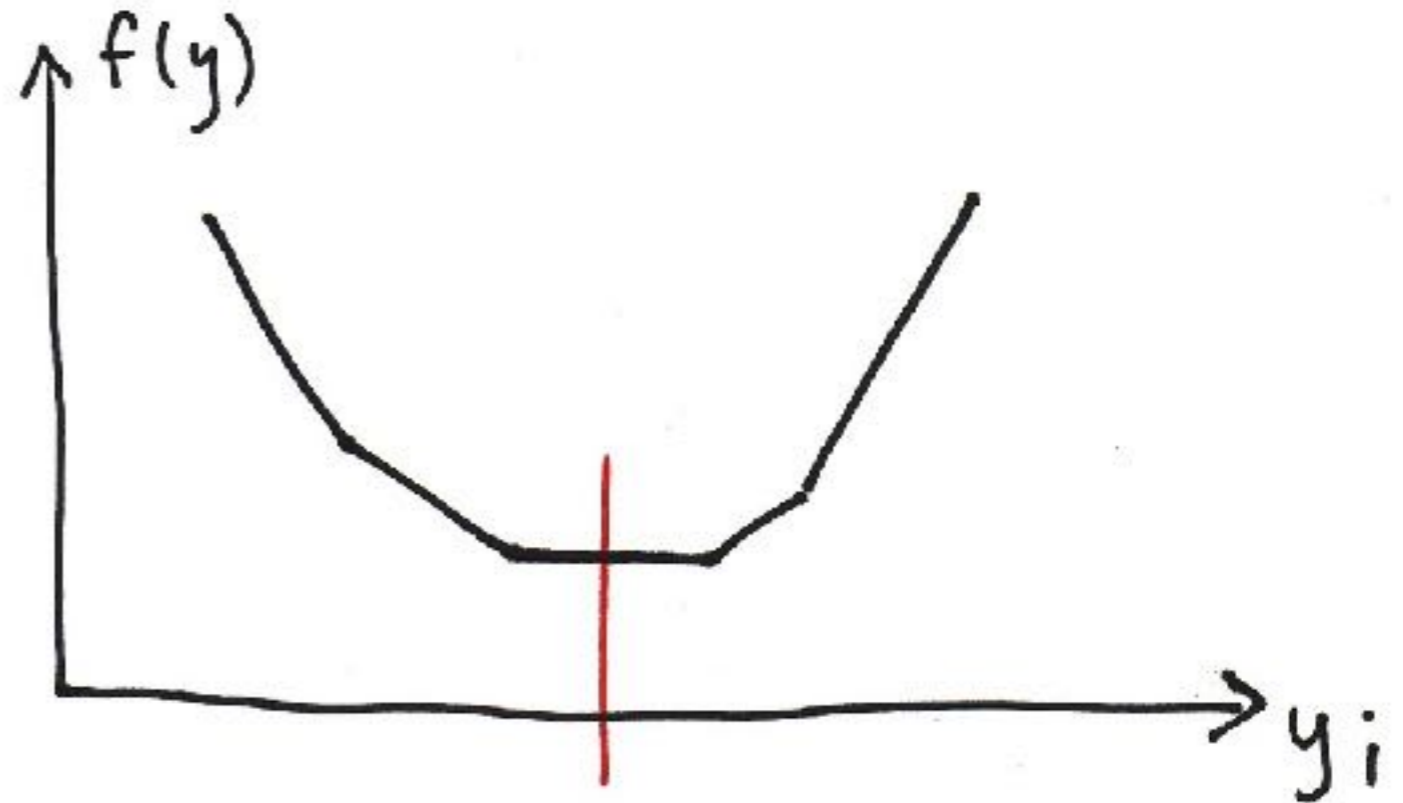

$$\min_y f(y) = yb + \max_{0 \leq x \leq 1} \bar{c}x$$

Aerolíneas Argentinas

BRITISH AIRWAYS
COMAIR

Lufthansa
MEXICANA

SINGAPORE AIRLINES CARGO
swiss
Swiss International Air Lines

AEROMEXICO

Continental Airlines

miami air
INTERNATIONAL

Spanair

AEROMEXICO connect

DB

Philippine Airlines

Thomson Airways

Aer Lingus

DELTA

QANTAS

الخطوط التونسية
TUNISAIR

airBaltic

DSB

FINNAIR

AIR CANADA

green cargo

AIRFRANCE

IBERIA

Air Wisconsin

KLM

Alaska Airlines

KLM Cityhopper

ASTAR AIR CARGO

LAN

QATAR AIRWAYS
القطرية

TURKISH AIRLINES

ASTAR AIR CARGO

الخطوط الجوية العربية السعودية
SAUDI ARABIAN AIRLINES

UNITED

ASTAR AIR CARGO

SAS Scandinavian Airlines

U.S AIRWAYS

ASTAR AIR CARGO

SINGAPORE AIRLINES

widerøe

ASTAR AIR CARGO

virgin atlantic

1990: “*datorn kan inte planera!*”

2000: “*optimization matters*”

A student project quite
long ago:

Scheduling system for
schools

not so easy...

Solving real problems mathematically - modelling!

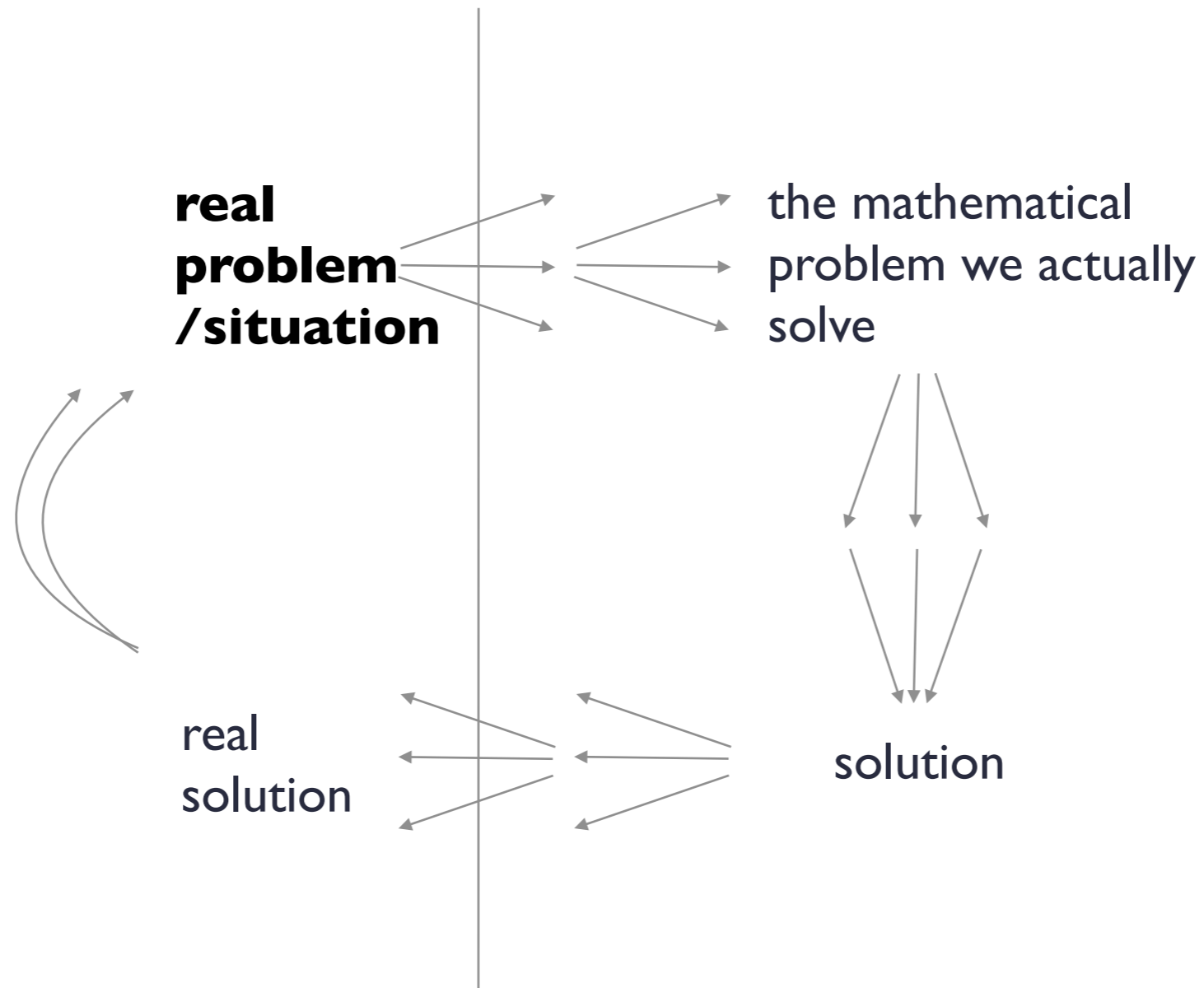

An iterative and creative design process!

Telephone operator problem (real applied problem)

A Swedish mobile phone operator needs to connect all base station to its main switch.

How can we best rent communication lines from the national fixed network?

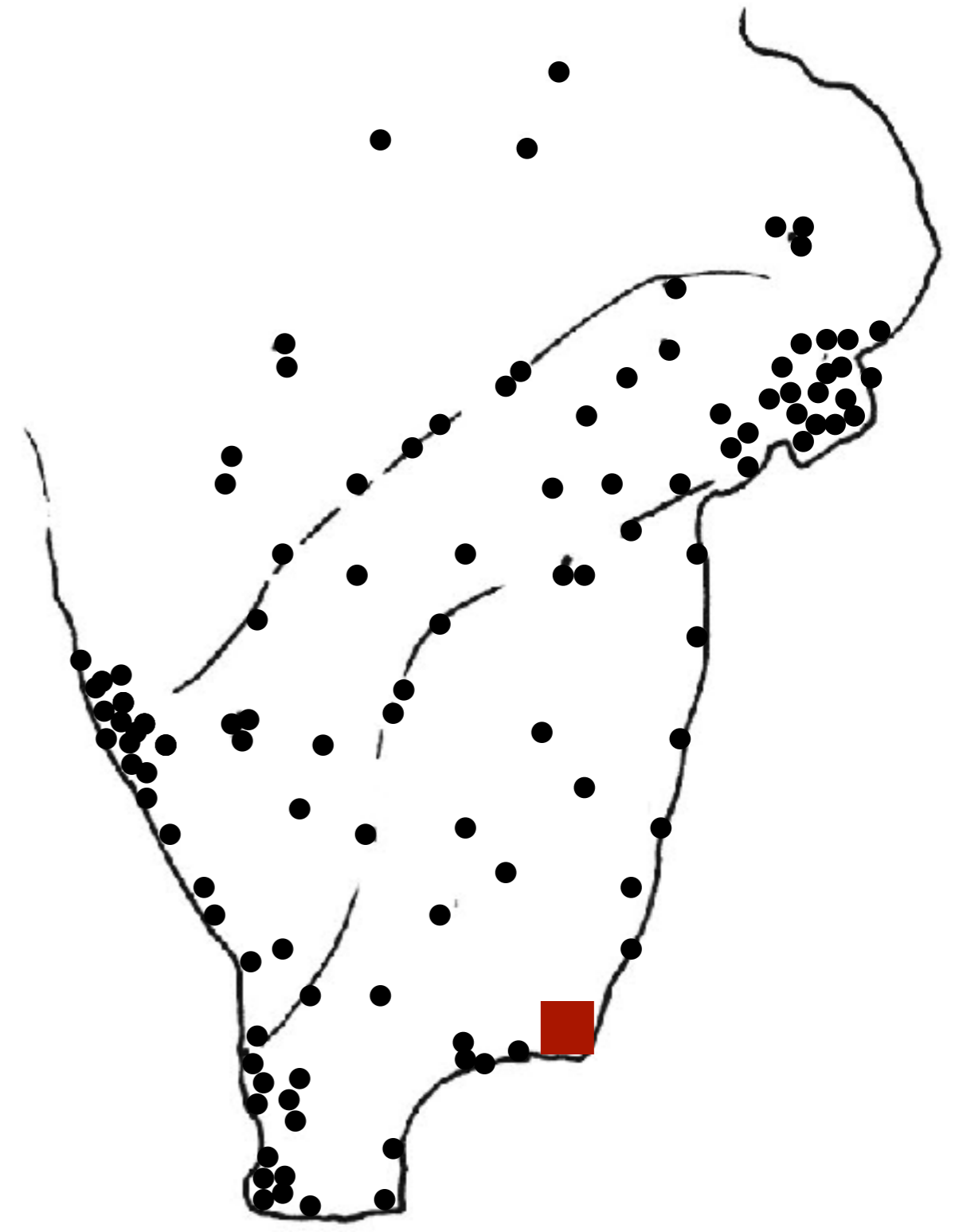

A simulation based arrival forecast algorithm for public transportation

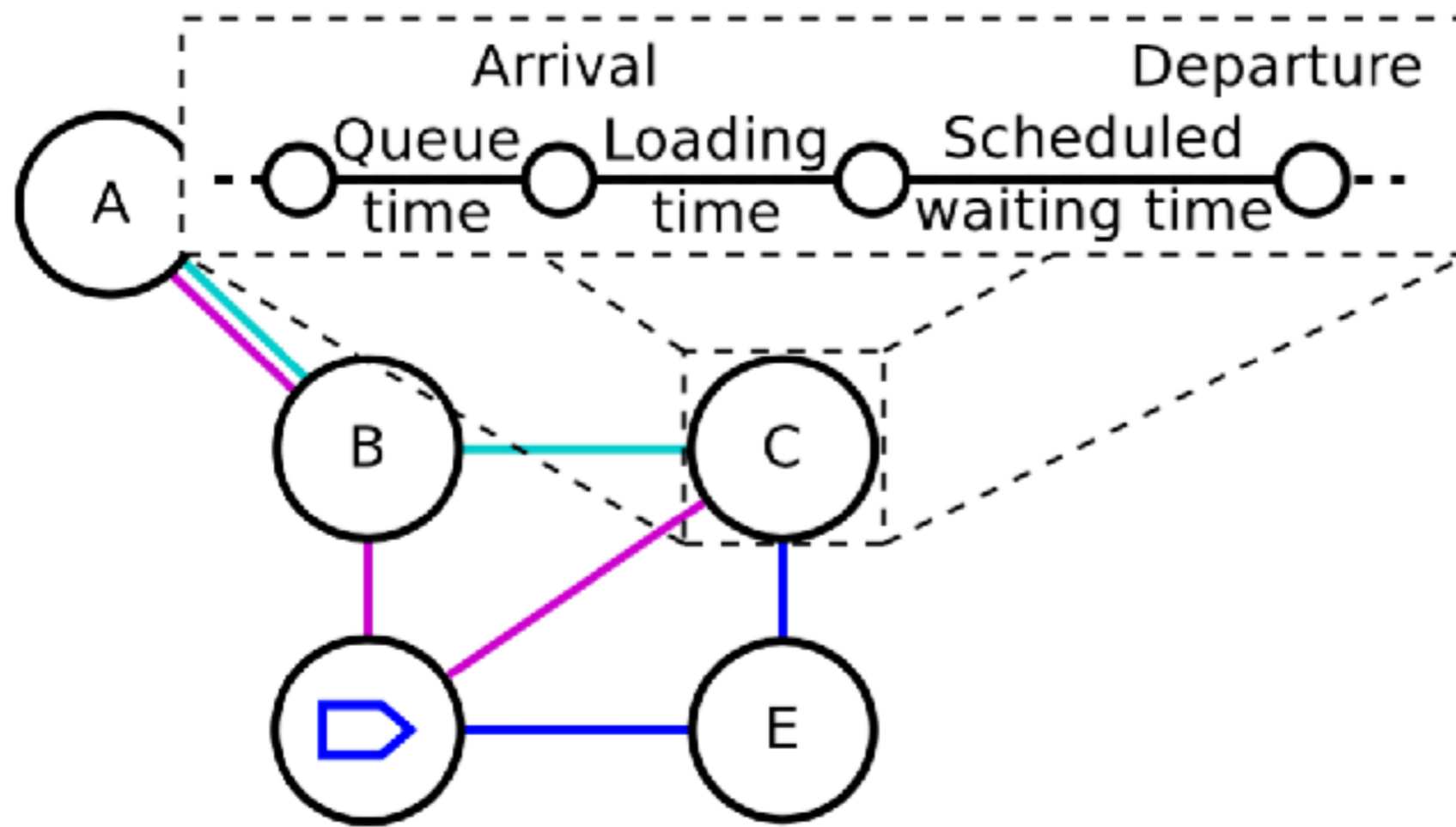

Figure 4.7: Dwell time is estimated by summing up the queue time, loading time and the scheduled waiting time. All these times are estimated separately.

Some recent master's theses

Driving context classification using
pattern recognition

Fördelning av
platsreservationer på tåg

Innovation in mathematics education -
a synthesis of the debate

In the past

main task to build basic IT-
infrastructure

significant hardware limitations

not always a very mathematical approach,
especially not in AI-applications

Today

now we want to do more things
with all the data we have!

no hardware limitations

considerable advances due to a more
mathematical approach e.g. in machine
learning

Some courses

mathematical modelling and
problem solving

algorithms

discrete optimization

machine learning

applied optimization

data science

AI

signal and image processing...

cryptography

simulation....

computer graphics

also more computer and
computation-oriented branches with
other kinds of math...

END