

Industrial Experiences from Multi-Paradigmatic Modelling of Signal Processing



**Håkan Burden,
Computer Science,
University of
Gothenburg**

**Rogardt Heldal,
Software Engineering,
Chalmers University of
Technology**

**Martin Lundqvist,
Baseband Research,
Ericsson AB**

Good enough languages

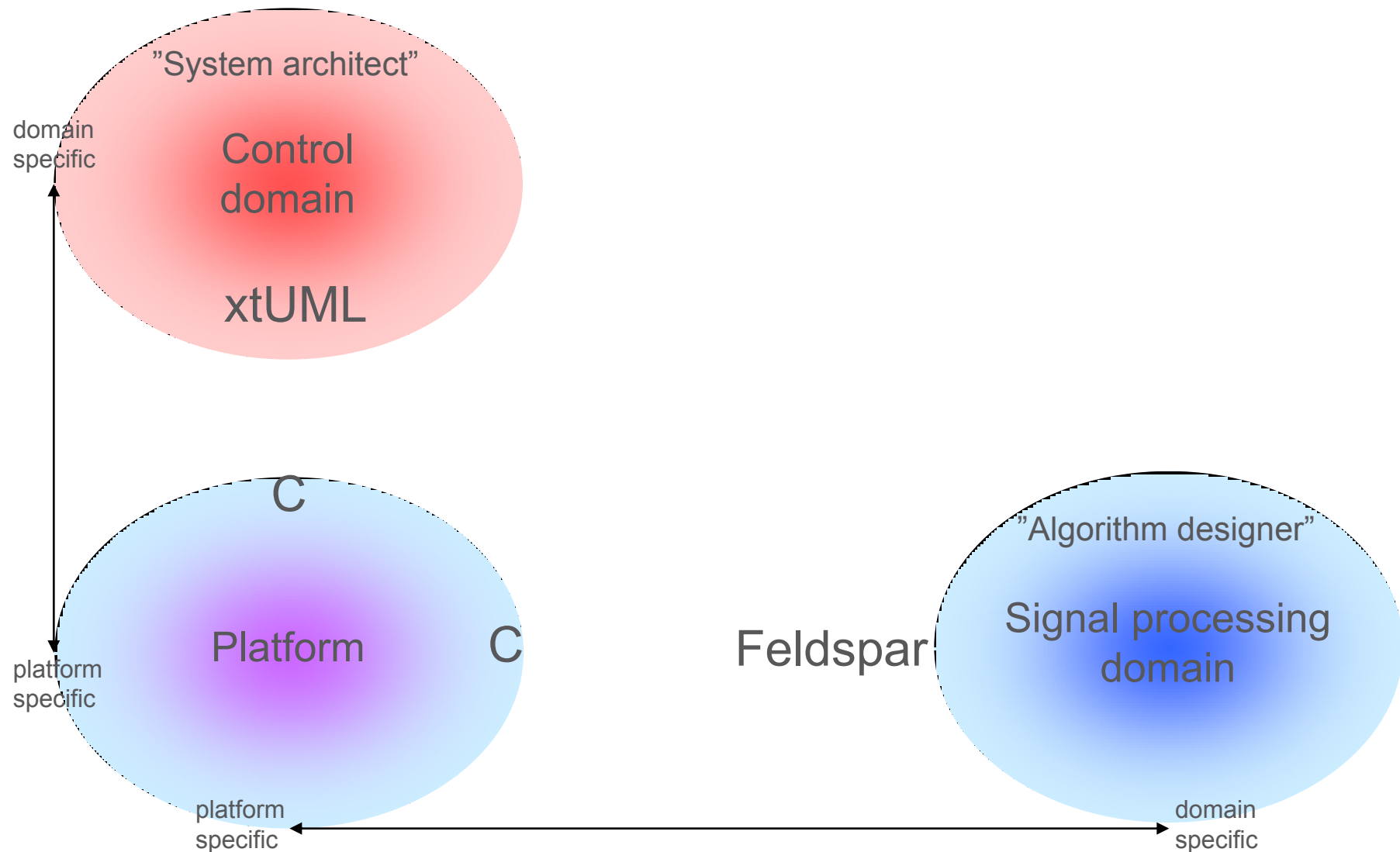

Domain interaction

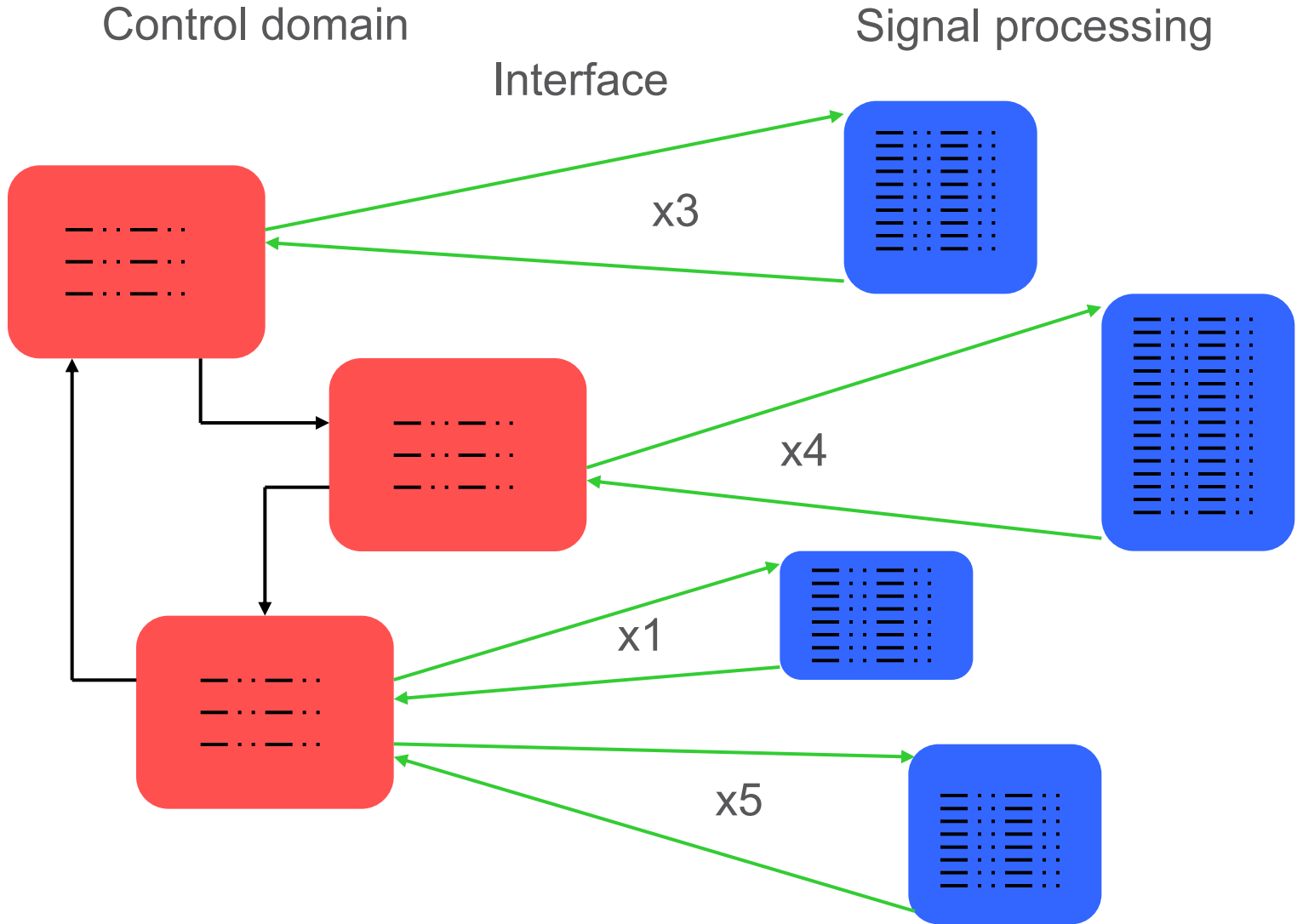

Integration and deployment

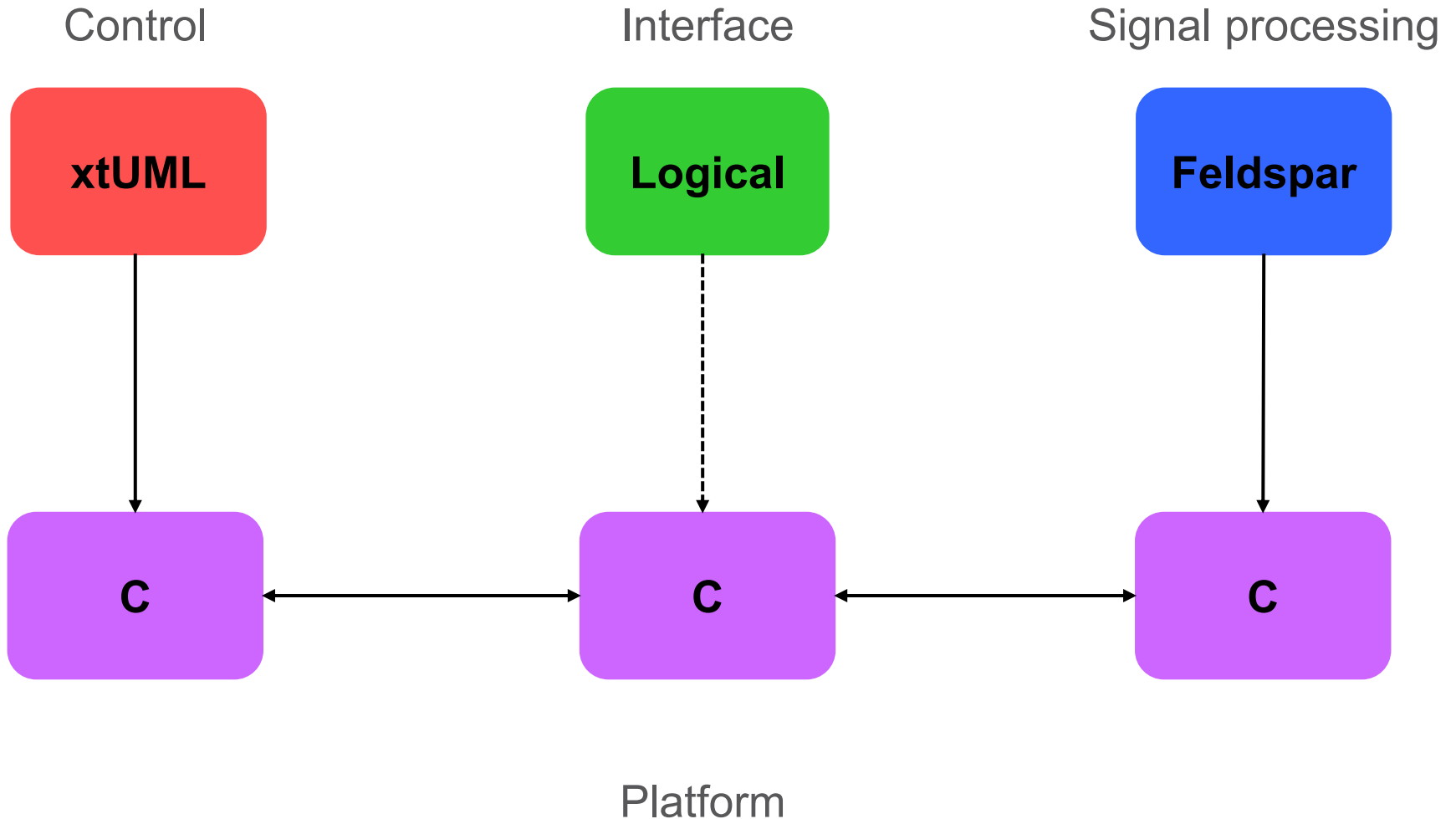

Conclusions

- + Clear domain separation
- + No side effects from Feldspar
- + Executable models

- Late integration testing
- Dependent on efficient transformations

- ? Languages close enough to domains
- ? Multicore
- ? New platforms
- ? Integration