

Databases in 88 Pages

Aarne Ranta

CSE, Chalmers University of Technology and University of
Gothenburg

Contents

1	Introduction*	7
1.1	Data vs. programs	7
1.2	A short history of databases	7
1.3	SQL	8
1.4	DBMS	9
1.5	Course contents	9
1.6	The big picture	12
2	Data modelling with relations	13
2.1	Relations and tables	13
2.2	Operations on relations	15
2.3	Multiple tables and joins	16
2.4	Referential constraints	17
2.5	Key and uniqueness constraints	17
2.6	Multiple values	18
2.7	Null values	19
3	Entity-Relationship diagrams	20
3.1	E-R syntax	20
3.2	From description to E-R	21
3.3	Converting E-R diagrams to database schemas	22
3.4	Using the Query Converter*	24
4	Functional dependencies and normal forms	27
4.1	The design workflow	27
4.2	Examples of dependencies and normal forms	28
4.2.1	Functional dependencies, keys, and superkeys	28
4.2.2	BCNF	29
4.2.3	3NF	30
4.2.4	4NF	30
4.2.5	A bigger example	31
4.2.6	One more example: FD or MVD?	32
4.3	Mathematical definitions of dependencies	33
4.4	Definitions of closures, keys, and superkeys	34
4.5	Definitions and algorithms for normal forms	34
4.6	Relation analysis in the Query Converter*	37
5	SQL	38
5.1	SQL in a nutshell	38
5.2	Database and table definitions	40
5.3	Inserting values	42
5.4	Query usage and semantics: simple queries	43
5.4.1	The cartesian product (FROM)	43
5.4.2	The condition on attributes (WHERE)	44

5.4.3	The projected tuples (SELECT)	45
5.4.4	Set operations on queries (UNION, INTERSECT, EXCEPT)	46
5.5	Query usage and semantics: more complex queries	46
5.5.1	Local definitions (WITH)	46
5.5.2	Sorting (ORDER BY)	47
5.5.3	Grouping (GROUP BY) and group conditions (HAVING)	47
5.5.4	Join operations (JOIN)	49
5.5.5	Pattern matching (LIKE)	51
5.6	Views (CREATE VIEW)	51
5.7	SQL pitfalls	51
5.8	SQL in the Query Converter*	53
6	Table modification and triggers	54
6.1	Active element hierarchy	54
6.2	Referential constraints and policies	55
6.3	CHECK constraints	56
6.4	ALTER TABLE	57
6.5	Triggers	57
7	Relational algebra and query compilation	60
7.1	The compiler pipeline	60
7.2	Relational algebra	60
7.3	From SQL to relational algebra	62
7.3.1	Basic queries	62
7.3.2	Grouping and aggregation	63
7.3.3	Sorting and duplicate removal	65
7.4	Query optimization	65
7.4.1	Algebraic laws	65
7.4.2	Example: pushing conditions in cartesian products	65
7.5	Relational algebra in the Query Converter*	66
8	SQL in software applications	67
8.1	SQL as a part of a bigger program	67
8.2	A minimal JDBC program*	67
8.3	Building queries and updates from input data*	69
8.4	SQL injection	70
8.5	The ultimate query language?*	71
9	Remaining SQL topics: transactions, authorization, indexes	73
9.1	Authorization and grant diagrams	73
9.2	Transactions	74
9.3	Interferences and isolation levels	75
9.4	Indexes	76

10 Alternative data models	79
10.1 XML and its data model	79
10.2 The XPath query language	83
10.3 XML and XPath in the query converter	84
10.4 NoSQL data models*	84
10.5 The Cassandra DBMS and its query language CQL*	85
10.6 Further reading on NoSQL*	87

Preface

These are notes for a databases course (TDA357/DIT620) taught in Gothenburg in 2016. They cover the material presented during the lectures. Similar material can also be found from course slides written by previous teachers. However, my personal preference is to use the blackboard rather than slides. This gives a better guarantee that the students (let alone the teacher) don't fall asleep. It also forces the lectures to have a natural, relaxed pace, with not too much information. For reading outside the lectures, a complete text works better than slides.

Just like slides published on course web sites, these course notes should eliminate the need to take your own notes about everything. Then you can concentrate more on listening and thinking. The best way to use these notes is to read them both before and after each lecture. Then you will be prepared for the material and maybe develop some questions in advance.

Even though these notes thus replace the slides, there are any number of things they don't replace:

- The course book. It has much more examples, explanations, and argumentation than this little compendium.
- The lectures. Attending the lectures should increase your understanding. However, reading these notes may compensate skipping a lecture or two for instance because of illness.
- Practice. To build a proper understanding, you must build and use your own database on a computer. You must also solve some theoretical problems by pencil and paper. The course assignments and exercises will help you get this practice - provided you do them yourself!

We will use a running example that deals with geographical data: countries and their capitals, neighbours, currencies, and so on. This is a bit different from many other slides, books, and articles. In them, you can find examples such as course descriptions, employer records, and movie databases. To my mind, such examples feel more difficult since they are not common knowledge. This means that, when learning new mathematical and programming concepts, you have to learn new content at the same time. I find it easier to study new technical material if the contents are familiar. For instance, it is easier to test a query that is supposed to assign "Paris" to "the capital of France" than a query that is supposed to assign "60,000" to "the salary of John Johnson". There is simply one thing less to keep in mind. It also eliminates to show example tables all the time, because we can simply refer to "the table containing all European countries and their capitals", which most readers will have clear enough in their minds. Of course, we will have the occasion to show other kinds of databases as well. The country database does not have all the characteristics that a database might have, for instance, very rapid changes in the data.

This compendium proceeds in the order of the lectures. It is being written during the course. My aim is to make every chapter available before the corresponding lecture is given. But I may also make corrections after the lecture. The sections marked with an asterisk (*) are ones that will not be needed for

the exam in Spring 2016.

The material has been inspired by the course book (Garcia-Molina, Ullman, and Widom, *Database systems: The Complete Book*), by earlier course material by Niklas Broberg and Graham Kemp, as well as by notes (in Finnish) by Jyrki Nummenmaa. I am grateful to Jyrki Nummenmaa and Grégoire Détrez on general advice and comments on the contents, and to Simon Smith, Adam Ingmansson, and Viktor Blomqvist for comments during the course. More comments, corrections, and suggestions are therefore most welcome - your name will be added here if you don't object!

Gothenburg, March 7, 2016

Aarne Ranta

1 Introduction*

This chapter is an overview of the field of databases and of this course. In addition to the material printed here, the lecture will also talk about practical questions such as assignments, exercises, and the exam. This information can be found on the course web page. The goal of this chapter (and the whole first lecture) is to give you a clear picture of what you are expected to do and learn during the course.

1.1 Data vs. programs

Computers run programs that process data. Sometimes this data comes from user interaction and is thrown away after the program is run. But often the data must be stored for a longer time, so that it can be accessed again. Banks, for instance, have to store the data about bank accounts so that no penny is lost.

It is typical that data lives much longer than the programs that process it: decades rather than just years. Programs, even programming languages, may be changed every five years or so. On the other hand, while data is maintained for decades, it may also be changed very rapidly. For instance, a bank can have millions of transactions daily, coming from ATM's, internet purchases, etc. This means that account balances must be continuously updated. At the same time, the history of transactions must be kept for years.

A **database** is any collection of data that can be accessed and processed by computer programs. It must support both **updates** (i.e. changes in the data) and **queries** (i.e. questions about the data). It must be **structured** so that these operations can be performed efficiently and accurately. For instance, English texts describing the data would be both too slow and too inaccurate. But the structure must also be **generic** enough so that it can be accessed in different ways. For instance, the data structures of some advanced programming language may be too hard to access from programs written in other languages.

1.2 A short history of databases

When databases came to wide use, for instance in banks in the 1960's, they were not yet standardized. They could be vendor specific, domain specific, or even machine specific. It was difficult to exchange data and maintain it when for instance computers were replaced. As a response to this situation, **relational databases** were invented in around 1970. They turned out to be both structured and generic enough for most purposes. They have a mathematical theory that is both precise and simple. Thus they are easy enough to understand by users and easy enough to implement in different applications. As a result, relational databases are often the most stable and reliable parts of information systems. They can also be the most precious ones, since they contain the results from decades of work by thousands of people.

Despite their success, relational databases have recently been challenged by other approaches. Some of the challengers want to support more complex data than relations. For instance, XML (Extended Markup Language) supports **hierarchical databases**, which were popular in the 1960's but were deemed too complicated by the proponents of relational databases. On the other end, **big data** applications have called for simpler models. In many applications, such as social media, accuracy and reliability are not so important as for instance in bank applications. Speed is much more important, and then the traditional relational models can be too rich. Non-relational approaches are known as **NoSQL**, by reference to the SQL language introduced in the next section.

1.3 SQL

Relational databases are also known as **SQL databases**. SQL is a computer language designed in the early 1970's, originally called Structured Query Language. The full name is seldom used: one says rather "sequel" or "es queue el". SQL is a **special purpose language**. Its purpose is to process of relational databases. This includes several operations:

- **queries**, asking questions, e.g. "what are the neighbouring countries of France"
- **updates**, changing entries, e.g. "change the currency of Estonia from Crown to Euro"
- **inserts**, adding entries, e.g. South Sudan with all the data attached to it
- **removals**, taking away entries, e.g. German Democratic Republic when it ceased to exist
- **definitions**, creating space for new kinds of data, e.g. for the main domain names in URL's

These notes will cover all these operations and also some others. SQL is designed to make it easy to perform them - easier than a **general purpose programming language**, such as Java or C. The idea is that SQL should be easier to learn as well, so that it is accessible for instance to bank employees without computer science training. However, as we will see, most users of databases today don't even need SQL. They use some **end user programs**, for instance an ATM interface with menus, which are simpler and less powerful than full SQL. These end user programs are written by programmers as combinations of SQL and general purpose languages.

Now, since a general purpose language could perform all operations that SQL can, isn't SQL superfluous? No, since SQL is a useful intermediate layer between user interaction and the data. One reason is the high level of abstraction in SQL. Another reason is that SQL implementations are highly optimized and reliable. A general purpose programmer would have a hard time matching the performance of them. Losing or destroying data would also be a serious risk.

1.4 DBMS

The implementations of SQL are called **database management systems** (DBMS). Here are some popular systems, in an alphabetical order:

- IBM DB2, proprietary
- Microsoft SQL Server, proprietary
- MySQL, open source, supported by Oracle
- Oracle, proprietary
- PostgreSQL, open source
- SQLite, open source

Each DBMS has a slightly different dialect of SQL. There is also an official standard, but no existing system implements all of it, or only it. In these notes, we will most of the time try to keep to the parts of SQL that belong to the standard and are implemented by at least most of the systems.

However, since we also have to do some practical work, we have to choose a DBMS to work in. The choice for the course in 2016 is PostgreSQL. Earlier courses have used Oracle, so this is in a way an experiment. The main reasons to try PostgreSQL are the following advantages over Oracle:

- it follows the standard more closely
- it is free and open source, hence easier to get hold of

1.5 Course contents

Lecture 1: Introduction

This is the chapter you are reading now. In addition to the material printed here, the lecture will talk about practical questions such as assignments, exercises, and the exam. This information can be found on the course web page. The goal of this chapter (and the whole first lecture) is to make it clear what you are expected to learn and to do during this course.

Lecture 2: Data modelling with relations

This chapter is about the representation of data in relational databases. Not all data is "naturally" relational, so that some encoding is necessary. Many things can go wrong in the encoding, and lead to redundancy or even to unintended data loss. This lecture gives several examples of different kinds of data. It introduces the notion of **relational schemas**, which are in SQL implemented by **table definitions**. But the level here is a bit more abstract than SQL. This chapter also explains the basics of the mathematics of relations, which are derived from set theory.

Lecture 3: Entity-Relationship diagrams

A popular device in modelling is **E-R diagrams** (Entity-Relationship diagrams). This chapter explains how different kinds of data are modelled by E-R diagrams. We will also tell how E-R diagrams can be constructed from

descriptive texts. Finally, we will explain how they are, almost mechanically, converted to relational schemes (and thereby eventually to SQL).

Lecture 4: Functional dependencies and normal forms

Mathematically, a relation can relate an object with many other objects. For instance, a country can have many neighbours. A function, on the other hand, relates each object with just one object. For instance, a country has just one number giving its area in square kilometres (at a given time). In this perspective, relations are more general than functions. However, it is important to acknowledge that some relations *are* functions. Otherwise, there is a risk of **redundancy**, repetition of the information. Redundancy can lead to **inconsistency**, if the information that should be the same in different places is actually not the same. This can happen for instance as a result of updates. But functional dependencies can help prevent this from happening. They can be used for transforming the database into a **normal form**, where redundancy is eliminated. There are many different normal forms, with weaker or stronger guarantees of consistency. This chapter will introduce three normal forms and two kinds of dependencies.

Lectures 5 and 6: SQL

Here we start getting our hands dirty with SQL. This chapter covers two lectures. At the first lecture, we will do some live coding in the PostgreSQL system. We will also explain the main language constructs of SQL. We will turn database schemas to SQL definitions. We will build a database by insertions. We will query it by selections, projections, joins, renamings, unions, intersections, etc. At the second lecture, we add SQL groupings and aggregations, as well as views. We will also take a look at low-level manipulations of strings and at the different datatypes of SQL.

Lecture 7: Table modification and triggers

Here we take a deeper look at inserts, updates, and deletions, in the presence of constraints. The integrity constraints of the database may restrict these actions or even prohibit them. An important problem is that when one piece of data is changed, some others may need to be changed as well. For instance, when value is deleted or updated, how should this affect other rows that reference it as foreign key? Some of these things can be guaranteed by constraints in basic SQL. But some things need more expressive power. For example, when making a bank transfer, money should not only be taken from one account, but the same amount must be added to the other account. For situations like this, DBMSs support **triggers**, which are programs that do many SQL actions at once.

Lecture 8: Relational algebra and query compilation

Relational algebra is a mathematical query language. It is much simpler than SQL, as it has only a few operations, each denoted by Greek letters. Being so simple, relational algebra is more difficult to use for complex queries than SQL. But for the very same reason, it is easier to analyse and optimize. Relational algebra is therefore useful as an intermediate language in a DBMS. SQL queries can be first translated to relational algebra, which is optimized before it is executed. This chapter will tell the basics about this translation and some query optimizations.

Lecture 9: SQL in software applications

End user programs are often built by combining SQL and a general purpose programming language. This is called **embedding**, and the general purpose language is called a **host language**. In this lecture, we will look at how SQL is embedded in Java. We will also cover some pitfalls in embedding. For instance **SQL injection** is a security hole where an end user can include SQL code in the data that she is asked to give. In one famous example, the name of a student includes a piece of SQL code that deletes all data from a student database.

Lecture 10: Remaining SQL topics: transactions, authorization, indexes

Repeating what was said before: SQL is a huge language, and the course does not cover all of it. This last SQL lecture is a "smörgåsbord" of things that have not been covered before. They are not covered in the course assignments either, but they may appear in the exam. Each of the topics moreover has some theoretical interest. Thus **transactions** are related to **concurrency**, where simultaneous database accesses by different users may create inconsistencies. **Authorization** is a systematic view on the permissions (read, write, etc) that different users can be given. **Indexes** are a way to make queries faster, at the cost of some more space and lower update speed. These concepts are introduced together with systematic ways of reasoning about the corresponding problems.

Lecture 11: Alternative data models

The relational data model has been dominating the database world for a long time. But there are alternative models, some of which are gaining popularity. XML is an old model, often seen as a language for documents rather than data. In this perspective, it is a generalization of HTML. But it is a very powerful generalization, which can be used for any structured data. XML data objects need not be just tuples, but they can be arbitrary trees. XML also has designated query languages, such as XPath and XQuery. This chapter introduces XML and gives a summary of XPath. On the other end of the scale, there are models simpler than SQL, known as "NoSQL" models. These models are popular in so-called big data applications, since they support the distribution

of data on many computers. NoSQL is implemented in systems like Cassandra, originally developed by Facebook and now also used for instance by Spotify.

1.6 The big picture

(figure to be improved :-)

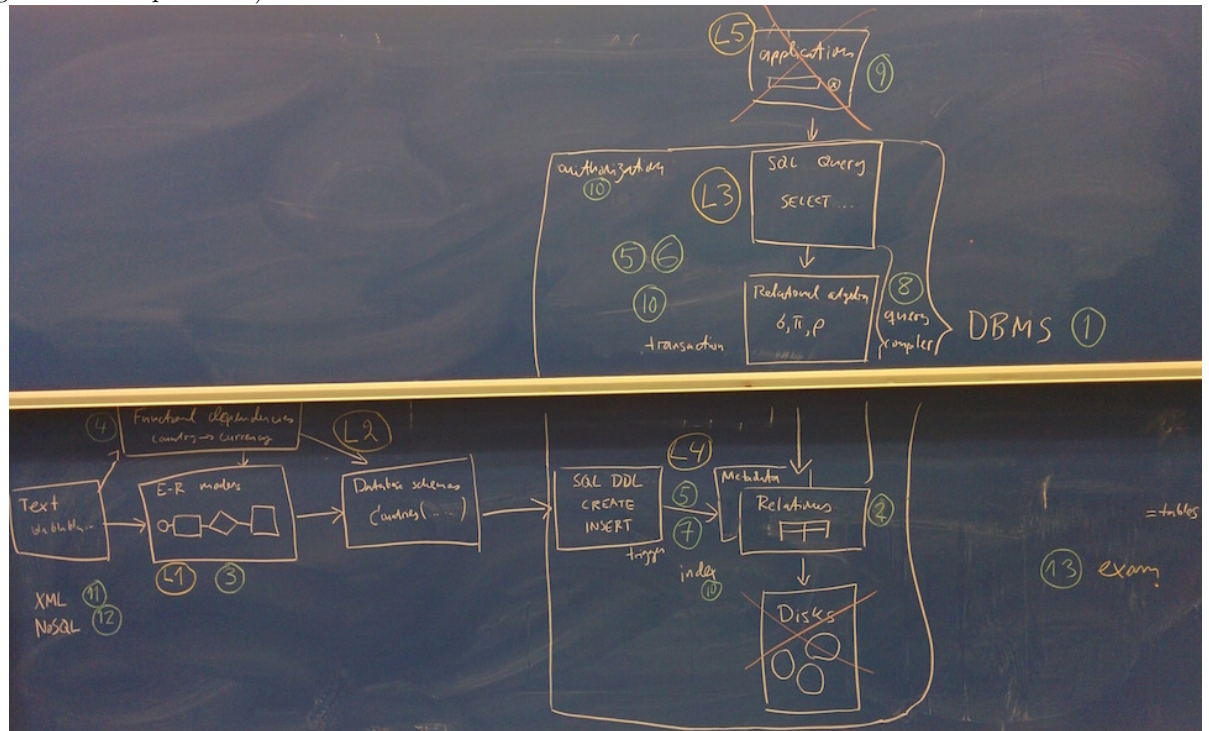

2 Data modelling with relations

*This chapter is about the representation of data in relational databases. Not all data is "naturally" relational, which means some encoding is necessary. Many things can go wrong in the encoding, and lead to redundancy, inconsistencies or even to unintended data loss. This chapter gives several examples of different kinds of data. It introduces the notion of **relational schemas**, which are in SQL implemented by **table definitions**. But the level here is a bit more abstract than SQL. This chapter also explains the basics of the mathematics of relations, which are derived from set theory.*

2.1 Relations and tables

The mathematical model of relational databases is, not surprisingly, relations. Mathematically, a relation is a subset of a **cartesian product** of sets:

$$R \subseteq T_1 \times \dots \times T_n$$

The elements of a relation are **tuples**, which we write in angle brackets:

$$\langle t_1, \dots, t_n \rangle \in T_1 \times \dots \times T_n \text{ if } t_1 \in T_1, \dots, t_n \in T_n$$

In these definitions, each T_i is a set. The elements t_i are the **components** of the tuple. The cartesian product of which the relation is a subset is its **signature**. The sets T_i are the **types** of the components.

In the database world, a relation is usually called a **table**. Tuples are called **rows**. Here is an example of a table and its mathematical representation:

country	capital	currency
Sweden	Stockholm	SEK
Finland	Helsinki	EUR
Estonia	Tallinn	EUR

$\{\langle \text{Sweden}, \text{Stockholm}, \text{SEK} \rangle, \langle \text{Finland}, \text{Helsinki}, \text{EUR} \rangle, \langle \text{Estonia}, \text{Tallinn}, \text{EUR} \rangle\}$

When seeing the relation as a table, it is also natural to talk about its **columns**. Mathematically, a column is the set of components from a given place i :

$$\{t_i \mid \langle \dots, t_i, \dots \rangle \in R\}$$

It is a special case of a **projection** from the relation. (The general case, as we will see later, is the projection of many components at the same time. The idea is the same as projecting a 3-dimensional object with xyz coordinates to a plane with just xy coordinates.)

What is the signature of this relation? What are the types of its components? For the time being, it is enough to think that every type is **String**. Then the signature is

$$\text{String} \times \text{String} \times \text{String}$$

However, database design can also impose more accurate types, such as 3-character strings for the currency. This is an important way to guarantee the quality of the data.

Now, what are "country", "capital", and "currency" in the table, mathematically? In databases, they are called **attributes**. In programming language terminology, they would be called **labels**, and the tuples would be **records**. Hence yet another representation of the table is a list of records,

```
[
  {country = Sweden, capital = Stockholm, currency = SEK},
  {country = Finland, capital = Helsinki, currency = EUR},
  {country = Estonia, capital = Tallinn, currency = EUR}
]
```

Mathematically, the labels can be understood as **indexes**, that is, indicators of the positions in tuples. (Coordinates, as in the *xyz* example is, also a possible name.) Given a cartesian product (i.e. a signature signature)

$$T_1 \times \dots \times T_n$$

we can fix a set of n labels (which are strings),

$$L = \{a_1, \dots, a_n\} \subset \text{String}$$

and an **indexing function**

$$i : L \rightarrow \{1, \dots, n\}$$

which should moreover be a bijection (i.e. a one-to-one correspondance). Then we can refer to each component of a tuple by using the label instead of the index:

$$t.a = t_{i(a)}$$

One advantage of labels is that we don't need to keep the tuples ordered. For instance, inserting a new row in a table in SQL by just listing the values without labels is possible, but risky, since we may have forgotten the order.

A **relation schema** consists of the name of the relation, the attributes, and the types of the attributes:

```
Countries(country : String, capital : String, currency : String)
```

The relation (table) itself is called an **instance** of the schema. The types will in this chapter and the next ones usually be omitted, so that we write

```
Countries(country, capital, currency)
```

But in real databases (and in SQL) the types are obligatory.

One thing that follows from the definition of relations as *sets* is that the order and repetitions are ignored. Hence for instance

country	capital	currency
Finland	Helsinki	EUR
Finland	Helsinki	EUR
Estonia	Tallinn	EUR
Sweden	Stockholm	SEK

is the same relation as the one above. SQL, however, makes a distinction, marked by the `DISTINCT` and `ORDER` keywords. This means that, strictly speaking, SQL tables are **lists** of tuples. If the order does not matter but the repetitions do, the tables are **multisets**.

In set theory, you should think of a relation as a *collection of facts*. The first fact is that Finland is a country whose capital is Helsinki and whose currency is EUR. Repeating this fact does not add anything. The order of facts does not mean anything either, since the facts don't refer to each other.

2.2 Operations on relations

Set theory provides some standard operations that are also used in databases:

$$\begin{array}{ll}
\mathbf{Union:} & R \cup S = \{t \mid t \in R \text{ or } t \in S\} \\
\mathbf{Intersection:} & R \cap S = \{t \mid t \in R \text{ and } t \in S\} \\
\mathbf{Difference:} & R - S = \{t \mid t \in R \text{ and } t \notin S\} \\
\mathbf{Cartesian product:} & R \times S = \{\langle t, s \rangle \mid t \in R \text{ and } s \in S\}
\end{array}$$

However, the database versions are a bit different from set theory:

- Union, intersection, and difference are only valid for relations that have the same schema.
- Cartesian products are **flattened**: $\langle \langle a, b, c \rangle, \langle d, e \rangle \rangle$ becomes $\langle a, b, c, d, e \rangle$

These standard operations are a part of **relational algebra**. They are also a part of SQL (with different notations). But in addition, some other operations are important - in fact, even more frequently used:

$$\begin{array}{ll}
\mathbf{Projection:} & \pi_{a,b,c} R = \{\langle t.a, t.b, t.c \rangle \mid t \in R\} \\
\mathbf{Selection:} & \sigma_C R = \{t \mid t \in R \text{ and } C\} \\
\mathbf{Theta join:} & R \bowtie_C S = \{\langle t, s \rangle \mid t \in R \text{ and } s \in S \text{ and } C\}
\end{array}$$

In selection and theta join, C is a **condition** that may refer to the tuples and their components. In SQL, they correspond to `WHERE` clauses. The use of attributes makes them handy. For instance.

$$\sigma_{\text{currency}=\text{EUR}} \text{Countries}$$

selects those rows where the currency is EUR, i.e. the rows for Finland and Estonia.

A moment's reflection shows that theta join can be defined as the combination of selection and cartesian product:

$$R \bowtie_C S = \sigma_C(R \times S)$$

The \bowtie symbol without a condition denotes **natural join**, which joins tuples that have the same values of the common attributes. It used to be the basic form of join, but it is less common nowadays. Actually, maybe it should be avoided because it relies on the names of attributes without making them explicit. But here is the definition if you want to see it:

$$R \bowtie_S = \{t + \langle u.c_1, \dots, u.c_k \rangle \mid t \in R, u \in S, (\forall a \in A \cap B)(t.a = u.a)\}$$

where A is the attribute set of R , B is the attribute set of S , and $B - A = \{c_1, \dots, c_k\}$. The $+$ notation means putting together two tuples into one flattened tuple.

An alternative definition expresses natural join in terms of theta join (exercise!). Thus we can conclude: natural join is a special case of theta join, which is a special case of the cartesian product.

2.3 Multiple tables and joins

The joining operator supports dividing data to multiple tables. Consider the following table:

Countries:

name	capital	currency	valueInUSD
Sweden	Stockholm	SEK	0.12
Finland	Helsinki	EUR	1.09
Estonia	Tallinn	EUR	1.09

This table has a **redundancy**, as the USD value of EUR is repeated twice. As we will see later, redundancy is usually avoided. For instance, someone might update the USD value of the currency of Finland but forget Estonia, which would lead to inconsistency. You can also think of the database as a story that states some facts about the countries. Normally you would only state once the fact that EUR is 1.09 USD.

Redundancy can be avoided by splitting the table into two:

JustCountries:

name	capital	currency
Sweden	Stockholm	SEK
Finland	Helsinki	EUR
Estonia	Tallinn	EUR

Currencies:

code	valueInUSD
SEK	0.12
EUR	1.09

Searching for the USD value of the currency of Sweden now involves a join of the two tables:

$$\pi_{\text{valueInUSD}}(\text{JustCountries} \bowtie_{\text{name=Sweden AND currency=code}} \text{Currencies})$$

To anticipate Chapter 5, this is how it would be written in SQL:

```
SELECT valueInUSD
FROM JustCountries, Currencies
WHERE name = 'Sweden' AND currency = code
```

Several things can be noted about this translation:

- The SQL operator SELECT corresponds to projection in relation algebra, not selection!
- In SQL, WHERE corresponds to selection in relational algebra.
- The FROM statement, listing any number of tables, actually forms their cartesian product.

Now, the SELECT-FROM-WHERE format is actually the most common idiom of SQL queries. As the FROM forms the cartesian product of potentially many tables, there is a risk that huge tables get constructed; keep in mind that the size of a cartesian products is the product of the sizes of its operand sets. The query compiler of the DBMS, however, can usually prevent this from happening by query optimization. In this optimization, it performs a reduction of the SQL code to something much simpler, typically equivalent to relational algebra code.

2.4 Referential constraints

The schemas of the two relations above are

```
JustCountries(country, capital, currency)
Currencies(code, valueInUSD)
```

For the **integrity** of the data, we want to require that all currencies in `JustCountries` exist in `Currencies`. We add to the schema a **referential constraint**,

```
JustCountries(country, capital, currency)
  currency -> Currencies.code
```

In the actual database, the referential constraint prevents us from inserting a currency in `JustCountries` that does not exist in `Currencies`.

2.5 Key and uniqueness constraints

A **key** of a relation is an attribute that determines all other attributes. A **composite key** is a set of attributes that together determine all others. We mark keys either by underlining or (in code ASCII text) with an underscore prefix.

```
JustCountries(_name, capital, currency)
    currency -> Currencies.code
```

```
Currencies(_code, valueInUSD)
```

In this example, `name` and `code` work naturally as keys. In `JustCountries`, `capital` could also work as a key, assuming that no two countries have the same capital. This could be stated by adding one more statement to the schema, a **uniqueness constraint**:

```
JustCountries(_name, capital, currency)
    currency -> Currencies.code
    unique capital
```

In the actual database, the key and uniqueness constraints prevent us from inserting a new country with the same name or capital.

In `JustCountries`, `currency` would not work as a key, because many countries can have the same currency.

In `Currencies`, `valueInUSD` *could* work as a key, if it is unlike that two currencies have exactly the same value. This would not be very natural of course. But the strongest reason of not using `valueInUSD` as a key is that we know that some day two currencies might well get the same value.

A key can also be **composite**. This means that many attributes together form the key. For example, in

```
PostalCodes(_city, _street, code)
```

the city and the street together determine the postal code, but the city alone is not enough. Nor is the street, because many cities may have the same street-name. For very long streets, we may have to look at the house number as well. The postal code determines the city but not the street. The code and the street together would be another possible composite key, but perhaps not very natural.

There is nothing that requires that all relations must have keys. Sometimes this is even impossible, unless one includes all attributes in a composite key. In many databases, **artificial keys** are therefore created. For instance, Sweden has introduced a system of "person numbers" to uniquely identify every resident of the country. Artificial keys may also be automatically generated by the system internally and never shown to the user. Then they are known as **surrogate keys**.

2.6 Multiple values

The guiding principle of relational databases is that all types of the components are **atomic**. This means that they may not themselves be tuples. This is what is guaranteed by the flattening of tuples of tuples in the relational version of the cartesian product. Another thing that is prohibited is list of values. Think about, for instance, of a table listing the neighbours of each country. You might be tempted to write something like

country	neighbours
Sweden	Finland, Norway
Finland	Sweden, Norway, Russia

But this is not possible, since the attributes cannot have list types. One has to write a new line for each neighbourhood relationship:

country	neighbour
Sweden	Finland
Sweden	Norway
Finland	Sweden
Finland	Norway
Finland	Russia

The elimination of complex values (such as tuples and lists) is known as the **first normal form**, 1NF. It is nowadays built in in relational database systems, where it is impossible to define attributes with complex values.

2.7 Null values

Sometimes a value is unknown or known not to exist. The word NULL can then be used. Null values have no clear meaning in set theory. They should generally be avoided, but sometimes they cannot.

3 Entity-Relationship diagrams

*A popular device in modelling is **E-R diagrams** (Entity-Relationship diagrams). This chapter explains how different kinds of data are modelled by E-R diagrams. We will also tell how E-R diagrams can almost mechanically be derived from descriptive texts. Finally, we will explain how they are, even more mechanically, converted to relational schemes (and thereby eventually to SQL).*

A relational database consists of a set of tables, which are linked to each other by referential constraints. This is a simple model to implement and flexible to use. But designing a database directly as tables can be hard, because only some things are "naturally" tables; some other things are more like relationships between tables, and might seem to require a more complicated model.

E-R modelling is a richer structure than just tables, but it can be converted to tables. Thus it helps design a database with right dependencies. When the E-R model is ready, it can be automatically converted to relational database schemas.

This chapter gives just the bare bones of E-R models. Their correct use is a skill that has to be practiced. This practice is particularly suited for work in pairs: you should discuss the model with your lab partner. You should debate, challenge and disagree. Sometimes there are many models that are equally good. But often a good-looking model is not so good if you take everything into account. Four eyes see more than two.

The course book contains valuable examples and discussions. You can find some more good examples in the old course slides. And of course, we will discuss and give examples during the lecture!

Figure 2 shows an example of an E-R diagram. We will hopefully add some other examples in later versions of these notes.

3.1 E-R syntax

Standard E-R models have six kind of elements, each drawn with different shapes:

entity	rectangle	a set of independent objects
relationship	diamond	between 2 ore more entities
attribute	oval	belongs to entity or relationship
ISA relationship	triangle	between 2 entities, no attributes
weak entity	double-sided rectangle	depends on other entities
weak relationship	double-sided rectangle	between weak entity and entity

Between elements, there are connecting lines:

- a relationship is connected to the entities that it relates
- an attribute is connected to the entity or relationship to which it belongs
- an ISA relationship is connected to the entities that it relates
- a weak relationship is connected to a weak entity and another (possibly weak) entity

Notice thus that there are no connecting lines directly between entities, or between relationships, or from an attribute to more than one element. The ISA relationship has no attributes. It is just a way to indicate that one entity is a **subentity** of another one.

The connecting lines from a relationship to entities can have arrowheads:

- sharp arrowhead: the relationship is to/from at most one object
- round arrowhead: the relationship is to/from exactly one object
- no arrowhead: the relationship is to/from many objects

The attributes can be underlined or, equivalently, prefixed by `_`. This means, precisely as in relation schemas, that the attribute is a part of a **key**. The keys of E-R elements end up as keys and referential constraints of schemas.

Here is a simple grammar for defining E-R diagrams. It is in the Extended BNF format, where `+` means 1 or more repetitions, `*` means 0 or more, and `?` means 0 or 1.

```
Diagram ::= Element+

Element ::=
    "ENTITY"           Name           Attributes
  | "WEAK" "ENTITY" Name Support+    Attributes
  | "ISA"              Name SuperEntity Attributes
  | "RELATIONSHIP"    Name RelatedEntity+ Attributes

Attributes ::=
    ":" Attribute*      # attributes start after colon
  |                     # no attributes at all, no colon needed

RelatedEntity ::= Arrow Entity (" Role ")? # optional role in parentheses
Support ::= Entity Relationship

Arrow ::= \--" | \->" | \-)"
Attribute ::= Ident | \_"Ident
Entity, SuperEntity, Relationship, Role ::= Ident
```

This grammar is useful in two ways:

- it defines exactly what combinations of elements are possible, so that you can avoid "syntax errors" (i.e. drawing impossible E-R diagrams)
- it can be used as input to a program that draws the diagrams and converts the model to a database schema (see below)

3.2 From description to E-R

The starting point of an E-R diagram is often a text describing the domain. You may have to add your own understanding to the text. The expressions used in the text may give clues to what kinds of elements to use. Here are some typical examples:

entity	CN (common noun)	"country"
attribute of entity	the CN of X	"the population of X"
attribute of relationship	adverbial	"in 1995"
relationship	TV (transitive verb)	"X exports Y"
relationship (more generally)	sentence with holes	"X lies between Y and Z"
subentity (ISA)	modified CN	"EU country"
weak entity	CN of CN	"city of X"

It is not always the case that just these grammatical forms are used. You should rather try if they are usable as alternative ways to describe the domain. For example, when deciding if something is an attribute of an entity, you should try if it really is *the* something of the entity, i.e. if it is unique. In this way, you can decide that *the population* is an attribute of a country, but *export product* is not.

You can also reason in terms of the informal semantics of the elements:

- An entity is an independent class of objects, which can have properties (attributes) as well as relationships to other entities.
- An attribute is a simple (atomic) property, such as name, size, colour, date. It belongs to only one entity.
- A relationship states a fact between two or more entities. These can also be entities of the same kind (e.g. "country X is a neighbour of country Y").
- A subentity is a special case of a more general entity. It typically has attributes that the general entity does not have. For instance, an EU country has the attribute "joining year".
- A weak entity is typically a part of some other entity. Its identity (i.e. key) needs this other entity to be complete. For instance, a city needs a country, since "Paris, France" is different from "Paris, Texas". The other entity is called **supporting entity**, and the relationships are **supporting relationships**. If the weak entity has its own key attributes, they are called **discriminators** (e.g. the name of the city).

3.3 Converting E-R diagrams to database schemas

The standard conversions are shown in Figure 1. The conversions are unique for ordinary entities, attributes, and many-to-many relationships.

- An entity becomes a relation with its attributes and keys just as in E-R.
- A relationship becomes a relation that has the key attributes of all related entities, as well as its own attributes.

Other kinds of elements have different possibilities:

- In exactly-one relationships, one can leave out the relationship and use the key of the related entity as attribute directly.
- In weak entities, one likewise leaves out the relationship, as it is always exactly-one to the strong entity.
- An at-most-one relationship can be treated in two ways:

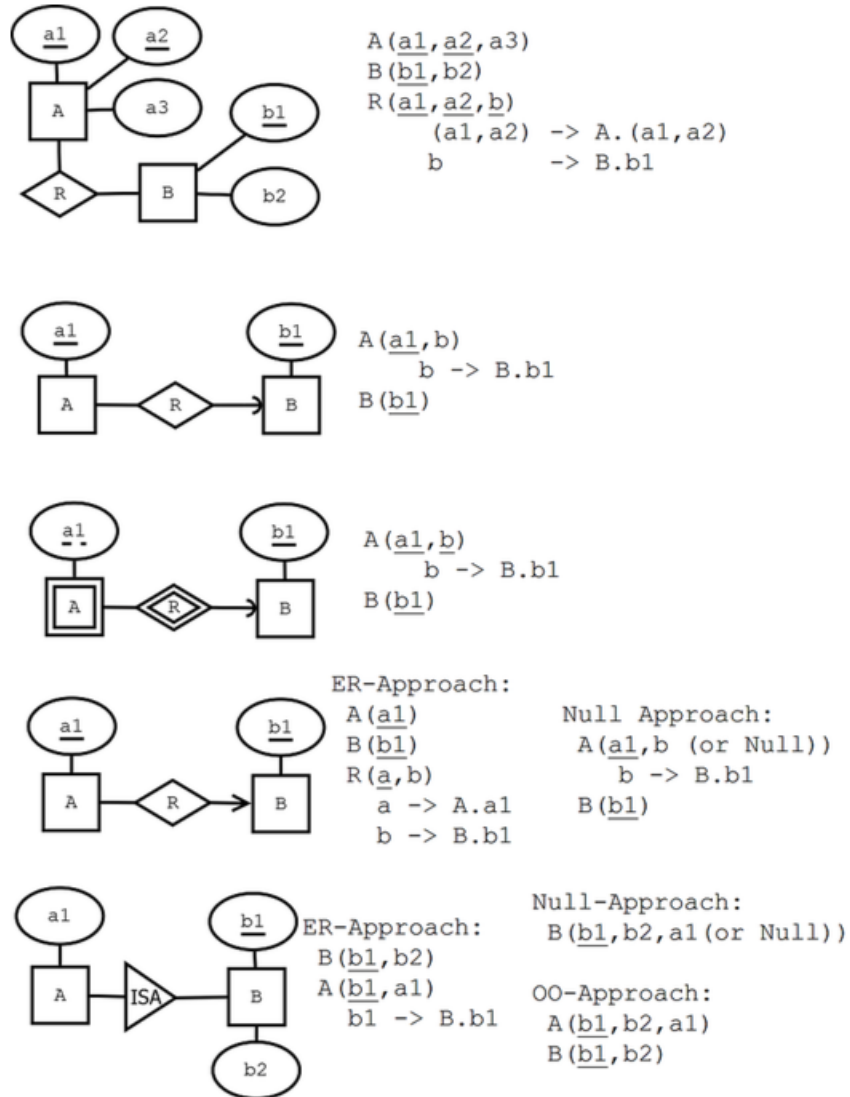

Figure 1: Translating E-R diagrams to database schemas. Picture by Jonas Almström-Duregård 2015.

- the NULL approach: the same way as exactly-one, allowing NULL values
- the (pure) E-R approach: the same way as to-many, preserving the relationship. No NULLs needed. However, the key of the related entity is not needed.
- An ISA relationship has three alternatives.
 - the NULL approach: just one table, with all attributes of all subentities. NULLs are needed.
 - the OO (Object-Oriented) approach: separate tables for each subentity and also for the superentity. No references between tables.
 - the E-R approach: separate tables for super-and subentity, subentity refers to the superentity.

As the name might suggest, the E-R approach is always recommended. It is the most flexible one, even though it requires more tables to be created.

One more thing: the naming of the tables of attributes.

- Entity names could be turned from singular to plural nouns.
- Attribute names must be made unique. (E.g. in a relationship from and to the same entity).

The course book actually uses plural nouns for entities, so that the conversion is easier. However, we have found it more intuitive to use singular nouns for entities, plural nouns for tables. The reason is that an entity is more like a kind (type), whereas a table is more like a list. The book uses the term **entity set** for entities, which is the set of entities of the given kind.

3.4 Using the Query Converter*

Notice: *The query converter is an experimental program that you might want to try. It is in no way compulsory for the course. We will show a live demo at the lecture. You can skip this section if you don't want to try the program.*

You can find the query converter (command `qconv`) in

<https://github.com/GrammaticalFramework/gf-contrib/tree/master/query-converter/>

You can specify an E-R model using the syntax described above. For example:

```
ENTITY Country _name : population
WEAK ENTITY City Country IsCityOf : _name population
ISA EUCountry Country : joiningDate
ENTITY Currency : _code name
RELATIONSHIP UsesAsCurrency -- Country -- Currency
```

If you have this text in the file `countries.txt`, then you can in `qconv` give the command

```
d countries.txt
```

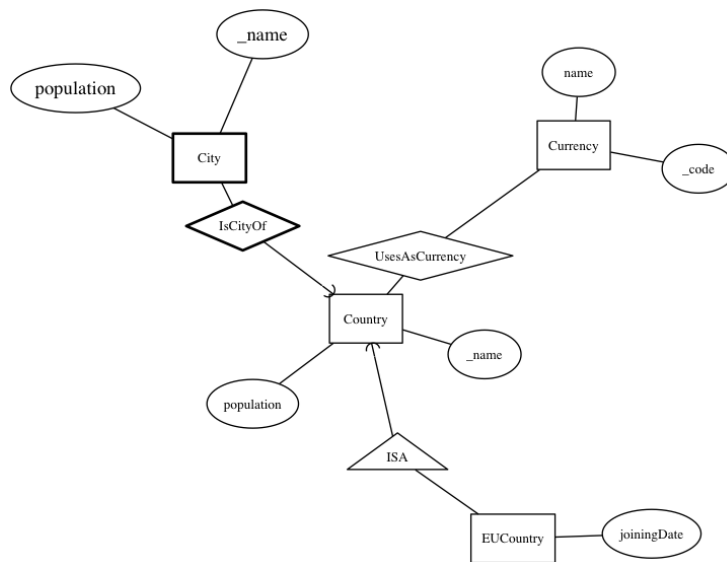



Figure 2: An E-R diagram generated from the Query Converter qconv. Weak entities and relationships have thick borders.

The result is a diagram shown in Figure 2. You can see it if you have installed the open-source Graphviz program. You will also get a database schema:

```

Country(_name,population)

City(_name,population,_name)
  name -> Country.name

EUCountry(_name,joiningDate)
  name -> Country.name

Currency(_code,name)

UsesAsCurrency(_countryName,_currencyCode)
  countryName -> Country.name
  currencyCode -> Currency.code
  
```

As an experimental feature, you will also get a text:

- A country has a name and a population.
- A city of a country has a name and a population.
- An eucountry is a country that has a joining date.
- A currency has a code and a name.
- A country can use as currency a currency.

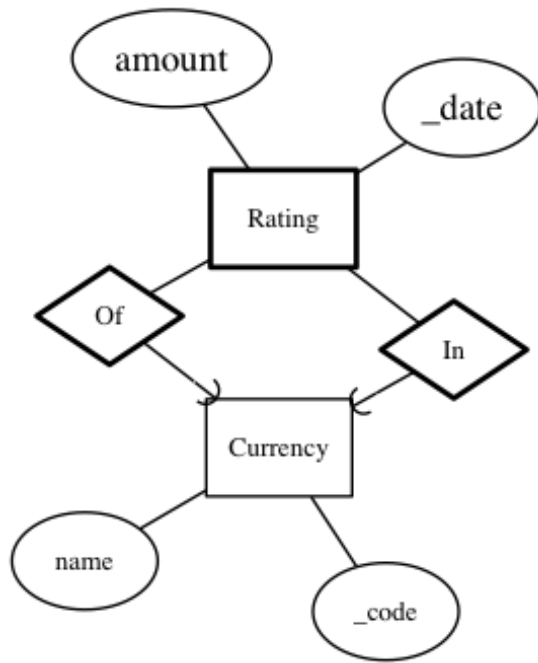

Figure 3: An E-R diagram for currency ratings, with two supporting relations.

Figure 3 shows another example, where the weak entity Rating has two supporting relations with Currency. This design was the result of a discussion at a lecture.

The Query Converter will be completed and improved during and after the course. It also has other functionalities: functional dependencies, normal forms, SQL, relational algebra.

4 Functional dependencies and normal forms

Mathematically, a relation can relate an object with many other objects. For instance, a country can have many neighbours. A function, on the other hand, relates each object with just one object. For instance, a country has just one number giving its area in square kilometres (at a given time). In this perspective, relations are more general than functions. However, it is important to acknowledge that some relations are functions. Otherwise, there is a risk of **redundancy**, repetition of the same information (in particular, of the same argument-value pair). Redundancy can lead to **inconsistency**, if the information that should be the same in different places is actually not the same. This can happen for instance as a result of updates, which is known as an **update anomaly**. But functional dependencies can help prevent this from happening. They can be used for transforming the database into a **normal form**, where redundancy is eliminated. There are many different normal forms, with weaker or stronger guarantees of consistency. This chapter will introduce three normal forms and two kinds of dependencies.

4.1 The design workflow

Functional dependency analysis is another tool for database design. It is quite different from E-R diagrams and should ideally be used independently of it. One way to do this (common in textbook examples), is the following procedure:

1. Collect *all* attributes into one and the same relation. At this point, it is enough to consider the relation as a set of attributes,

$$S = \{A_1, \dots, A_n\}$$

2. Specify the functional dependencies and multivalued dependencies among the attributes. Informally,
 - a **functional dependency** (FD) $A \rightarrow B$ means that, if you set the value of A , there is only one possible value of B s. This generalizes to sets of attributes on both sides of the arrow.
 - a **multivalued dependency** (MVD) $A \twoheadrightarrow B$ means that, the value of B depends only on the value of A . But there can be many values. This generalizes to sets of attributes on both sides of the arrow. The exact definition of MVD is a bit tricky, and MVD analysis is less common than FD analysis.
1. From the functional dependencies, calculate the possible **keys** of the relation. Informally,
 - a **key** is a combination X of attributes such that $X \rightarrow S$, i.e. all attributes of the relation are determined by the attributes in X .
1. From the FDs, MVDs, and keys together, calculate the **violations of normal forms**. In summary,
 - violations of the **third normal form** (3NF) result from FDs
 - violations of the **Boyce-Codd normal form** (BCNF) likewise result from FDs

- violations of the **fourth normal form** (4NF) result from MVDs

1. From the normal form violations, compute a **decomposition** of the relation to a set of smaller relations. These smaller relations each have their own FDs, MVDs, and keys. But it is always possible to reach a state with no violations by iterating the decomposition. The result is a set of tables, each with their own keys, which have no violations.
2. Decide what decomposition you want. All normal forms have their pros and cons. At this point, you may want to compare the dependency-based design with the E-R design.

Dependency-based design is, in a way, more mechanical than E-R design. In E-R design, you have to decide many things: the ontological status of each concept (whether it is an entity, attribute, relationship, etc). You also have to decide the keys of the entities. In dependency analysis, you only have to decide the basic dependencies. Lots of other dependencies are derived from these by mechanical rules. Also the possible keys - **candidate keys** - are mechanically derived. The decomposition to normal forms is mechanical as well. You just have to decide what normal form (if any) you want to achieve. In addition, you have to decide which of the candidate keys to declare as the **primary key** of each table.

4.2 Examples of dependencies and normal forms

4.2.1 Functional dependencies, keys, and superkeys

Let us start with a table of countries, currencies, and values of currencies (in USD, on a certain day).

country	currency	value
Sweden	SEK	0.12
Finland	EUR	1.10
Estonia	EUR	1.10

We assume that each country has a unique currency, and each currency has a unique value. This gives us two functional dependencies:

```
country -> currency
currency -> value
```

The dependencies are much like implications in the logical sense. Thus they are **transitive**, which means that we can also infer the FD

```
country -> value
```

The set of attributes that can be inferred from a set of attributes X is the **closure** of X . Thus, since **value** can be inferred from **country**, it belongs to its closure. In fact,

```
country+ = {country, currency, value}
```

noticing that $A \rightarrow A$ is always a valid FD, called **trivial functional dependency**.

Now, a possible key of a relation is a set of attributes whose closure is the whole signature. Thus **country** alone is a possible key. However, it is not the only set that determines all attributes. All of

```
country
country currency
country value
country currency value
```

do this. However, all of these sets but the first are just irrelevant extensions of the first. They are not keys but **superkeys**, i.e. supersets of keys. We conclude that **country** is the only possible key of the relation.

4.2.2 BCNF

What to do with the other functional dependency, **currency** \rightarrow **value**? We could call it a **non-key FD**, which is not standard terminology, but a handy term. Looking at the table, we see that it creates a **redundancy**: the value is repeated every time a currency occurs. Non-key FD's are called **BCNF violations**. They can be removed by **BCNF decomposition**: we build a separate table for each such FD. Here is the result:

country	currency
Sweden	SEK
Finland	EUR
Estonia	EUR

currency	value
SEK	0.12
EUR	1.10

These tables have no BCNF violations, and no redundancies either. Each of them has their own functional dependencies and keys:

```
Countries (_country, currency)
FD: country  $\rightarrow$  currency
reference: currency  $\rightarrow$  Currencies.currency
```

```
Currencies (_currency, value)
FD: currency  $\rightarrow$  value
```

They also enjoy **lossless join**: we can reconstruct the original table by a natural join $\text{Countries} \bowtie \text{Currencies}$.

4.2.3 3NF

Now, let us consider an example where BCNF is not quite so beneficial. Here is a table with cities, streets, and postal codes.

city	street	code
Gothenburg	Framnäsgatan	41264
Gothenburg	Rännvägen	41296
Gothenburg	Hörsalsvägen	41296
Stockholm	Barnhusgatan	11123

Here is the signature with functional dependencies:

```
city street code
city street -> code
code -> city
```

The keys are the composite keys `city street` and `code street`. But notice that the non-key FD `code -> city` refers back to a key. If we now perform BCNF decomposition, we obtain the schemas

```
Cities(_code, city)
FD: code -> city
```

```
Streets(_street, _code)
```

The problem with this decomposition is that we miss one FD, `city -> street -> code`. And in fact, the decomposition does not help remove redundancies. The original relation is fine as it is. It is already in the **third normal form** (3NF). 3NF is like BCNF, except that a non-key FD $X \rightarrow A$ is allowed if A is a part of some key. Here, `city` is a part of a key, so it is fine. (An attribute that is a part of a key is called **prime**.)

The 3NF requirement is weaker than BCNF, but it does not guarantee the removal of all FD redundancies. In many cases, the result is actually the same: the country-currency-value table is an example.

4.2.4 4NF

Multivalued dependencies (MVD) are another kind of dependencies. An MVD $X \twoheadrightarrow Y$ says that X determines Y independently of all other attributes. (The precise definition is a bit complicated, and is given in a later section.)

Here is an example: a table of countries, their export products, and countries to which the produces are exported:

country	product	exportTo
Sweden	cars	Norway
Sweden	paper	Denmark
Sweden	cars	Denmark
Sweden	paper	Norway

In this table, Sweden exports both cars and paper to both Denmark and Norway. More generally, we can assume as a fact about the domain that, whatever a country exports to some other country, it also exports to all other countries that it has trade with. Hence the MVD

country ->> product

Now, the table has a redundancy: both cars and paper and Norway and Denmark are mentioned repeatedly. We can in fact find an **4NF violation**: an MVD where the LHS is not a superkey. The **4NF decomposition** splits the table in accordance to the violating MVD:

country	product
Sweden	cars
Sweden	paper

country	exportTo
Sweden	Norway
Sweden	Denmark

These tables are free from violations. Hence they are in 4NF. Their natural join losslessly returns the original table.

In the previous example, we could actually prove the MVD by looking at the tuples (see definition of MVD below). Finding a provable MVD in an instance of a database can be difficult, because so many combinations must be present. An MVD might of course be assumed to hold as a part of the domain description. This can lead to a better structure and smaller tables. However, the natural join from those tables can produce unwanted results.

4.2.5 A bigger example

Let us collect everything about a domain into one big table:

country capital popCountry popCapital currency value product exportTo

We identify some functional dependencies and multivalued dependencies:

country -> capital popCountry currency
 capital -> country popCapital
 currency -> value
 country ->> product

One possible BCNF decomposition gives the following tables:

_country capital popCountry popCapital currency
 _currency value
 _country _product _exportTo

This looks like a good structure, except for the last table. Applying 4NF decomposition to this gives the final result

```
_country capital popCountry popCapital currency
_currency value
_country _product _exportTo
_country _exportTo
```

A word of warning: mechanical decomposition can randomly choose some other dependencies to split on, and lead to less natural results. For instance, it can use capital rather than country as keys in the tables.

In the two sections that follow, we will show the precise algorithms that are involved, and which you should learn to execute by hand. The definitions might look more scary than they actually are. Most of the concepts are intuitively simple, but their precise definitions can require some details that one usually doesn't think about. The notion of MVD is usually the most difficult one.

In the last section, we will look at the support given by the Query Converter (`qconv`) for dependency analysis and normal form decomposition.

4.2.6 One more example: FD or MVD?

(A similar example was treated with an MVD in the first version of these notes. But this turned out to be overkill: the same result can be achieved without the MVD.)

How should we model the neighbours of a country?

```
country population currency neighbour
```

We can assume that country determines the population and the currency. Hence the FD

```
country -> population currency
```

But what about the neighbours? Surely a country can have many neighbours, so there is no FD here. But aren't the neighbours independent of the population and the currency? Then we would add the MVD

```
country ->> neighbour
```

However, recalling that (1) all FDs are are MVDs, and (2) MVDs are symmetric (see the definitions below), this MVD is actually a consequence of the FD! Hence adding it does not give anything new to our analysis.

In fact, the only key of the relation is `country neighbour`. This implies that the FD is a 3NF violation. Both 3NF and BCND decomposition give the same nice result:

```
country population currency
country neighbour
```

4.3 Mathematical definitions of dependencies

Before introducing new concepts, we will repeat some of the definitions about tuples from Chapter 2. We will most of the time speak of relations just as their sets of attributes. Also the dependency algorithms refer only to the attributes. But the definitions in the end do refer to tuples. By tuples, we will now mean labelled tuples (records) rather than set-theoretic ordered tuples as in Chapter 2.

Definition (tuple, attribute, value). A **tuple** has the form

$$\{A_1 = v_1, \dots, A_n = v_n\}$$

where A_1, \dots, A_n are **attributes** and v_1, \dots, v_n are their **values**.

Definition (signature, relation). The **signature** of a tuple, S , is the set of all its attributes, $\{A_1, \dots, A_n\}$. A **relation** R of signature S is a set of tuples with signature S . But we will sometimes also say "relation" when we mean the signature itself.

Definition (projection). If t is a tuple of a relation with signature S , the **projection** $t.A_i$ computes to the value v_i .

Definition (simultaneous projection). If X is a set of attributes $\{B_1, \dots, B_m\} \subseteq S$ and t is a tuple of a relation with signature S , we can form a simultaneous projection,

$$t.X = \langle t.B_1, \dots, t.B_m \rangle$$

Definition (functional dependency, FD). Assume X is a set of attributes and A an attribute, all belonging to a signature S . Then A is **functionally dependent** on X in the relation R , written $X \rightarrow A$, if

- for all tuples t, u in R , if $t.X = u.X$ then $t.A = u.A$.

If Y is a set of attributes, we write $X \rightarrow Y$ to mean that $X \rightarrow A$ for every A in Y .

Definition (multivalued dependency, MVD). Let X, Y, Z be disjoint subsets of a signature S such that $S = X \cup Y \cup Z$. Then Y has a **multivalued dependency** on X in R , written $X \twoheadrightarrow Y$, if

- for all tuples t, u in R , if $t.X = u.X$ then there is a tuple v in R such that
 - $v.X = t.X$
 - $v.Y = t.Y$
 - $v.Z = u.Z$

An alternative notation is $X \twoheadrightarrow Y \mid Z$, emphasizing that Y is **independent** of Z .

To see the power of these definitions, we can now easily prove a slightly surprising result saying that every FD is an MVD:

Theorem. If $X \rightarrow Y$ then $X \twoheadrightarrow Y$

Proof. Assume that t, u are tuples in R such that $t.X = u.X$. We select $v = u$. This is a good choice, because

- 1 $u.X = t.X$ by assumption
- 2 $u.Y = t.Y$ by the functional dependency $X \rightarrow Y$
- 3 $u.Z = u.Z$ by reflexivity of identity.

Note. MVDs are symmetric on their right hand side: if $X \twoheadrightarrow Y$, which means $X \twoheadrightarrow Y \mid Z$ where $Z = S - X - Y$, then also $X \twoheadrightarrow Z$. Thus in the previous example we could have written, equivalently,

country ->> exportedTo

4.4 Definitions of closures, keys, and superkeys

As a starting point of dependency analysis, a relation is characterized by its signature S , its functional dependencies FD, and its multivalued dependencies MVD. We start with things where we don't need MVD.

Assume thus a signature (i.e. set of attributes) S and a set FD of functional dependencies.

Definition. An attribute A **follows** from a set of attributes Y , if there is an FD $X \rightarrow A$ such that $X \subseteq Y$.

Definition (closure of a set of attributes under FDs). The **closure** of a set of attributes $X \subseteq S$ under a set FD of functional dependencies, denoted X^+ , is the set of those attributes that follow from X .

Algorithm (closure of attributes). If $X \subseteq S$, then the closure X^+ , can be computed in the following way:

1. Start with $X^+ = X$
2. Set $New = \{A \mid A \in S, A \notin X^+, A \text{ follows from } X^+\}$
3. If $New = \emptyset$, return X^+ , else set $X^+ = X^+ \cup New$ and go to 1

Definition (closure of a set of FDs). The closure of a set FD of functional dependencies, denoted by FD^+ , is defined as follows:

$$FD^+ = \{X \rightarrow A \mid X \subseteq S, A \in X^+, A \notin X\}$$

The last condition excludes trivial functional dependencies.

Definition (trivial functional dependencies). An FD $X \rightarrow A$ is **trivial**, if $A \in X$.

Definition (superkey, key). A set of attributes $X \subseteq S$ is a **superkey** of S , if $S \subseteq X^+$.

A set of attributes $X \subseteq S$ is a **key** of S if

- X is a superkey of S
- no proper subset of X is a superkey of S

4.5 Definitions and algorithms for normal forms

Definition (Boyce-Codd Normal Form, BCNF violation). A functional dependency $X \rightarrow A$ **violates BCNF** if

- X is not a superkey
- the dependency is not trivial

A relation is in **Boyce-Codd Normal Form** (BCNF) if it has no BCNF violations.

Note. Any trivial dependency $A \rightarrow A$ always holds even if A is not a superkey.

Definition (prime). An attribute A is prime if it belongs to some key.

Definition (Third Normal Form, 3NF violation). A functional dependency $X \rightarrow A$ **violates 3NF** if

- X is not a superkey
- the dependency is not trivial
- A is not prime

Note. 3NF is a weaker normal form than BCNF: Any violation $X \rightarrow A$ of 3NF is also a violation of BCNF, because it says that X is not a superkey. Hence, any relation that is in BCNF is also in 3NF.

Definition (trivial multivalued dependency). A multivalued dependency $X \twoheadrightarrow A$ is trivial if $Y \subseteq X$ or $X \cup Y = S$.

Definition (Fourth Normal Form, 4NF violation). A multivalued dependency $X \twoheadrightarrow A$ **violates 4NF** if

- X is not a superkey
- the MVD is not trivial.

Note. 4NF is a stronger normal form than BCNF: If $X \twoheadrightarrow A$ violates BCNF, then it also violates 4NF, because

- it is an MVD by the theorem above
- it is not trivial, because
 - if $\{A\} \subseteq X$, then $X \rightarrow A$ is a trivial FD and cannot violate BCNF
 - if $X \cup \{A\} = S$, then X is a superkey and $X \rightarrow A$ cannot violate BCNF

Algorithm (BCNF decomposition). Consider a relation R with signature S and a set F of functional dependencies. R can be brought to BCNF by the following steps:

1. If R has no BCNF violations, return R
2. If R has a violating functional dependency $X \rightarrow A$, decompose R to two relations
 - $R1$ with signature $X \cup \{A\}$
 - $R2$ with signature $S - \{A\}$
3. Apply the above steps to $R1$ and $R2$ with functional dependencies projected to the attributes contained in each of them.

One can combine several violations with the same left-hand-side X to produce fewer tables. Then the violation $X \rightarrow Y$ decomposes R to $R1(X, Y)$ and $R2(S - Y)$.

Note. Step 3 of the BCNF decomposition algorithm involves the **projection of functional dependencies**. This can in general be a complex procedure. However, for most cases handled during this course, it is enough just to filter out those dependencies that do not appear in the new relations.

Algorithm (4NF decomposition). Consider a relation R with signature S and a set M of multivalued dependencies. R can be brought to 4NF by the following steps:

1. If R has no 4NF violations, return R
2. If R has a violating multivalued dependency $X \twoheadrightarrow Y$, decompose R to two relations

- $R1$ with signature $X \cup \{Y\}$
- $R2$ with signature $S - Y$

3. Apply the above steps to $R1$ and $R2$

Note. This algorithm has the same structure as the BCNF decomposition. For 3NF decomposition, a very different algorithm is used, seemingly with no iteration. But a involved iteration can be needed to compute the *minimal basis* of the FD set.

Concept (minimal basis of a set of functional dependencies; not a rigorous definition). A **minimal basis** of a set F of functional dependencies is a set F' that implies all dependencies in F . It is obtained by first weakening the left hand sides and then dropping out dependencies that follow by transitivity. Weakening an LHS in $X \rightarrow A$ means finding a minimal subset of X such that A can still be derived from F' .

Algorithm (3NF decomposition). Consider a relation R with a set F of functional dependencies.

1. If R has no 3NF violations, return R .
2. If R has 3NF violations,
 - compute a minimal basis of F' of F
 - group F' by the left hand side, i.e. so that all dependencies $X \rightarrow A$ are grouped together
 - for each of the groups, return the schema $XA_1 \dots A_n$ with the common LHS and all the RHSs
 - if one of the schemas contains a key of R , these groups are enough; otherwise, add a schema containing just some key

Example (minimal basis). Consider the schema

```
country currency value
country -> currency
country -> value
currency -> value
```

It has one 3NF violation: **currency -> value**. Moreover, the FD set is not a minimal basis: the second FD can be dropped because it follows from the first and the third ones. Hence we have a minimal basis

```
country -> currency
currency -> value
```

Applying 3NF decomposition to this gives us two schemas:

```
country currency
currency value
```

i.e. exactly the same ones as we would obtain by BCNF decomposition. These relations are hence not only 3NF but also BCNF.

4.6 Relation analysis in the Query Converter*

The `qconv` command `f` reads a relation from a file and prints out relation info:

- the closure of functional dependencies
- superkeys
- keys
- normal form violations

The command `n` reads a relation from the same file format and prints out decompositions in 3NF, BCNF, and 4NF.

The format of these files is as in the following example:

```
country capital popCountry popCapital currency value product exportTo
country -> capital popCountry currency
capital -> popCapital
currency -> value
country ->> product
```

The Haskell code in

<https://github.com/GrammaticalFramework/gf-contrib/blob/master/query-converter/Fundep.hs>

is a direct rendering of the mathematical definitions. There is a lot of room for optimizations, but as long as the number of attributes is within the usual limits of textbook exercises, the naive algorithms work perfectly well.

5 SQL

Here we start getting our hands dirty with SQL. This chapter covers two lectures. At the first lecture, we will do some live coding in the PostgreSQL system. We will also explain the main language constructs of SQL. We will turn database schemas to SQL definitions. We will build a database by insertions. We will query it by selections, projections, joins, renamings, unions, intersections, etc. At the second lecture, we add SQL groupings and aggregations, as well as views. We will also take a look at low-level manipulations of strings and at the different datatypes of SQL.

NOTE: This chapter is not an SQL tutorial, but an overview of the syntax and semantics of the language. We do give some examples of SQL usage, but focus more on possibly surprising things than the common usage. The book gives many more examples, and there is a detailed on-line tutorial in

<http://www.w3schools.com/sql/>

This tutorial also has a nice index of SQL keywords.

5.1 SQL in a nutshell

Figure 4 shows a grammar of SQL. It is not full SQL, but it does contain all those constructs that are used in this course for database definitions and queries. The syntax for triggers, indexes, authorizations, and transactions will be covered in later chapters.

In addition to the standard constructs, different DBMSs contain their own ones, thus creating "dialects" of SQL. They may even omit some standard constructs. In this respect, PostgreSQL is closer to the standard than many other systems.

The grammar notation aimed for human readers. It is hence not completely formal. A full formal grammar can be found e.g. in PostgreSQL references:

<http://www.postgresql.org/docs/9.5/interactive/index.html>

Another place to look is the Query Converter source file

<https://github.com/GrammaticalFramework/gf-contrib/blob/master/query-converter/MinSQL.bnf>

It is roughly equivalent to Figure 4, and hence incomplete. But it is completely formal and is used for implementing an SQL parser.¹

The grammar is BNF (Backus Naur form) with the following conventions:

- CAPITAL words are SQL keywords, to take literally
- small character words are names of syntactic categories, defined each in their own rules

¹ The parser is generated by using the BNF Converter tool, <http://bnfc.digitalgrammars.com/> which is also used for the relational algebra and XML parsers in qconv.

```

statement ::=
  CREATE TABLE tablename (
    * attribute type inlineconstraint*
    * [CONSTRAINT name]? constraint
  ) ;
|
  DROP TABLE tablename ;
|
  INSERT INTO tablename tableplaces? values ;
|
  DELETE FROM tablename
  ? WHERE condition ;
|
  UPDATE tablename
  SET setting+
  ? WHERE condition ;
|
  query ;
|
  CREATE VIEW viewname
  AS ( query ) ;
|
  ALTER TABLE tablename
  + alteration ;
|
  COPY tablename FROM filepath ;
  ## postgresql-specific, tab-separated

query ::=
  SELECT DISTINCT? columns
  ? FROM table+
  ? WHERE condition
  ? GROUP BY attribute+
  ? HAVING condition
  ? ORDER BY attributeorder+
|
  query setoperation query
|
  query ORDER BY attributeorder+
  ## no previous ORDER in query
|
  WITH localdef+ query

table ::=
  tablename
| table AS? tablename ## only one iteration allowed
| ( query ) AS? tablename
| table jointype JOIN table ON condition
| table jointype JOIN table USING (attribute+)
| table NATURAL jointype JOIN table

condition ::=
  expression comparison compared
| expression NOT? BETWEEN expression AND expression
| condition boolean condition
| expression NOT? LIKE 'pattern*'
| expression NOT? IN values
| NOT? EXISTS ( query )
| expression IS NOT? NULL
| NOT ( condition )

expression ::=
  attribute
| tablename.attribute
| value
| expression operation expression
| aggregation ( DISTINCT? *(attribute)
  ( query )

value ::=
  integer | float | 'string'
| value operation value
| NULL

type ::=
  CHAR ( integer ) | VARCHAR ( integer ) | TEXT
| INT | FLOAT

inlineconstraint ::= ## not separated by commas!
  PRIMARY KEY
| REFERENCES tablename ( attribute ) policy*
| UNIQUE | NOT NULL
| CHECK ( condition )
| DEFAULT value

constraint ::=
  PRIMARY KEY ( attribute+ )
| FOREIGN KEY ( attribute+ )
  REFERENCES tablename ( attribute+ ) policy*
| UNIQUE ( attribute+ ) | NOT NULL ( attribute )
| CHECK ( condition )

policy ::=
  ON DELETE|UPDATE CASCADE|SET NULL
  ## alternatives: CASCADE and SET NULL

tableplaces ::=
  ( attribute+ )

values ::=
  VALUES ( value+ ) ## keyword VALUES only in INSERT
| ( query )

setting ::=
  attribute = value

alteration ::=
  ADD COLUMN attribute type inlineconstraint*
| DROP COLUMN attribute

localdef ::=
  WITH tablename AS ( query )

columns ::=
  * ## literal asterisk, select all columns
| column+

column ::=
  expression
| expression AS name

attributeorder ::=
  attribute (DESC|ASC)?

setoperation ::=
  UNION | INTERSECT | EXCEPT

jointype ::=
  LEFT|RIGHT|FULL OUTER?
| INNER?

comparison ::=
  = | < | > | <> | <= | >=

compared ::=
  expression
| ALL|ANY values

operation ::=
  + | - | * | / | %
| || ## literal two bars, string concat

pattern ::=
  % | _ | character ## matching any string, any char
| [ character* ]
| [^ character* ]

aggregation ::=
  MAX | MIN | AVG | COUNT | SUM

```

Figure 4: A grammar of the main SQL constructs.

- | separates alternatives
 - + means one or more, separated by commas
 - * means zero or more, separated by commas
 - ? means zero or one
 - in the beginning of a line, + * ? operate on the whole line; elsewhere, they operate on the word just before
 - ## start comments, which explain unexpected notation or behaviour
 - other symbols, e.g. parentheses, mean literal parts of SQL code (except in || and * operators)
 - parentheses can be added to disambiguate the scopes of operators
- Another important aspect of SQL syntax is **case insensitivity**:
- **keywords** are usually written with capitals, but can be written by any combinations of capital and small letters
 - the same concerns **identifiers**, i.e. names of tables, attributes, constraints
 - however, **string literals** in single quotes are case sensitive

5.2 Database and table definitions

Logically, the creation of a database starts with a statement

```
CREATE DATABASE dbname ;
```

But you will seldom see this statement. If you use the school's PostgreSQL installation, you already have a database created, and you should work under that. If you are administrating your own PostgreSQL installation, you may use the Unix shell command

```
createdb dbname
```

After this, you can start PostgreSQL with the Unix shell command

```
psql dbname
```

Once a database is created, tables can be added by CREATE TABLE statements. These statements implement the database schemas as discussed in earlier chapters. Unlike in schemas, types are compulsory, but keys are not.

This leads us to a translation from relation schemas to SQL statements. The general form of a schema is

```
relation ( attribute , ... , attribute )
  foreignAttribute -> relation.attribute
  ...
  foreignAttribute -> relation.attribute
```

This is converted to the SQL statement

```

CREATE TABLE relation (
  attribute type,
  ...
  attribute type,
  PRIMARY KEY ( keyAttributes ),
  FOREIGN KEY ( foreignAttribute ) REFERENCES relation (attribute),
  ...
  FOREIGN KEY ( foreignAttribute ) REFERENCES relation (attribute)
)

```

where each type is selected in a suitable way. The "primary key" is the set of all key attributes. The "foreign keys" can also be grouped into tuples.

As for the types, SQL has several types for strings: CHAR(n), VARCHAR(n), and TEXT. In earlier times, and in other DBMSs, these types may have performance errors. However, the PostgreSQL manual says as follows: "There are no performance differences between these types... In most situations text or character varying = should be used." Following this advice, we will in the following use TEXT as the only string type. Objects of all the three types are string literals in single quotes (e.g. 'foo bar'). Spaces are preserved.

Example:

```

Countries (_name,capital,population,currency)
  capital -> Cities.name
  currency -> Currencies.code

```

gives

```

CREATE TABLE Countries (
  name TEXT,
  capital TEXT,
  population INT,
  currency TEXT,
  PRIMARY KEY (name),
  FOREIGN KEY (capital) REFERENCES Cities (name),
  FOREIGN KEY (currency) REFERENCES Currencies (code)
)

```

In addition to these schema elements, some other constraints can be added. For example, in this case, the following would make sense:

```

UNIQUE (capital),
NOT NULL (capital)

```

as a way to express that capital is another candidate key of Countries. This is told us by the functional dependencies, but only one set of attributes can be the PRIMARY KEY. Notice that UNIQUE, unlike PRIMARY KEY, does not imply NOT NULL, so this must be stated separately.

Constraints can also be given names:

```
CONSTRAINT primaryKeyName PRIMARY KEY (name)
```

This may help get better error messages. It also makes it possible to remove constraints later if needed. At the opposite end of verbosity are **inline constraints**, which are stated together with the attributes they concern:

```
name TEXT PRIMARY KEY
```

More on constraints will follow in Chapter 6, where in particular the CHECK constraints are discussed.

5.3 Inserting values

The INSERT INTO statement works with both value lists and queries. Here is a list:

```
INSERT INTO Places VALUES ('Oslo','Norway','60N')
```

where the fields must match the schema of Places; we could here assume

```
Places (name TEXT, country TEXT, latitude TEXT)
```

If we want to quickly populate Places by the capitals of countries, we can do

```
INSERT INTO Places (SELECT capital,name FROM Countries)
```

This will leave the `latitude` attribute undefined. Alternatively, we can initialize the latitude with a value, e.g. `'0'` (because this is the longest latitude on the globe and therefore the most probable choice ;-):

```
INSERT INTO Places (SELECT capital,name,'0' FROM Countries)
```

As yet another alternative, the CREATE TABLE statement could have specified a **default** for latitude with an inline constraint,

```
latitude TEXT DEFAULT '0'
```

There are always many ways of expressing the things in SQL! (However, DEFAULT constraints cannot appear separately in the usual way but must be inlined.)

In PostgreSQL, there is a quick way to insert values from tab-separated files:

```
COPY tablename FROM filepath
```

Notice that a complete filepath is required. The data in the file must of course match your database schema. To give an example, if you have a table

```
Countries (name,capital,area,population,continent,currencycode,currencyname)
```

you can read data from a file that looks like this:

Andorra	Andorra la Vella	468	84000	EU	EUR	Euro
United Arab Emirates	Abu Dhabi	82880	4975593	AS	AED	Dirham
Afghanistan	Kabul	647500	29121286	AS	AFN	Afghani

The file

<https://github.com/GrammaticalFramework/gf-contrib/blob/master/query-converter/countries.tsv>

can be used for this purpose. It is extracted from the Geonames database, <http://www.geonames.org/>

An alternative method is to generate lots of INSERT commands into a file. Such a file can also include other SQL commands - you can, for instance, save all your work in it. Then you can build your database, or parts of it, with the PostgreSQL command

```
\i file.sql
```

5.4 Query usage and semantics: simple queries

This section covers the part of SQL presented on Lecture 5.

The most common form of a query is

```
SELECT attributes
FROM tables
WHERE condition
```

It corresponds to the relational algebra expression

$$\pi_{\text{attributes}}\sigma_{\text{condition}}(\text{table} \times \dots \times \text{table})$$

Thus, to understand its meaning, it should be read in the order in which the processing happens:

```
FROM tables WHERE condition SELECT attributes
```

Notice that only the SELECT part is compulsory; you can use it on an expression that doesn't refer to any table:

```
SELECT 2+2
```

5.4.1 The cartesian product (FROM)

Here we list the table names we want to query about. If the same table is used twice, it can be given different names:

```
SELECT A.name, B.capital
FROM Countries AS A, Countries AS B
WHERE A.name = B.capital
```

shows countries that have the same name as some other country's capital.

A table can also be given as a subquery. In this case, it is obligatory to give it a name.

```
SELECT name
FROM (
    SELECT name, capital
    FROM countries) AS C
WHERE C.name = C.capital
```

shows countries that have the same name as their capital. (The subquery is rather superfluous in this very example, though.)

In addition to table names and subqueries, tables formed by different JOIN operations can be included. More on this in Section 5.5.4.

5.4.2 The condition on attributes (WHERE)

Conditions are boolean-valued expressions. The WHERE clause filters those tuples that make the condition TRUE. The conditions are built by

- comparison operators (such as =, <, <>, (NOT) LIKE) from **expressions** referring **values** in tuples
 - a special kind of comparison is with ALL and ANY, compared to a list of values or a subquery.
`x < ALL (2,3,4)`
means that x is at most 1. If we change ALL to ANY, then x must be at most 3.
- query-related operators (NOT) EXISTS and (NOT) IN from subqueries
- logical operators (AND, OR, NOT) from conditions

The operand expressions can be

- **literals** (strings, integers, floats)
- attributes, possibly qualified with table names
- built from other expressions with arithmetic operations (+, -, etc)
- subqueries returning exactly one atomic values, e.g.

```
(SELECT capital FROM Countries WHERE name = 'Sweden')
```

More precisely, conditions have a three-valued logic, because of the presence of NULL. Comparisons with NULL always result in NULL. Logical operators have the following meanings (T = TRUE, F = FALSE, U = UNKNOWN)

p	q	NOT p	p AND q	p OR q
T	T	F	T	T
T	F	”	F	T
T	U	”	U	T
F	T	T	F	T
F	F	”	F	F
F	U	”	F	U
U	T	U	U	T
U	F	”	F	U
U	U	”	U	U

A tuple satisfies a WHERE clause only if it returns T, not one with U. Keep in mind, in particular, that NOT U = U!

5.4.3 The projected tuples (SELECT)

The projected tuples can be formed in several ways:

- attributes from the FROM clause, either bare or qualified
- expressions involving the attributes
- both of these with new names (expr AS name)

For instance, the following selects big countries with size just marked **big**:

```
SELECT name, 'big' AS size
FROM Countries
WHERE population > 50000000
```

The expressions may involve **aggregation** operators: COUNT, AVG, SUM, MIN, MAX. For instance,

```
SELECT SUM(population)
FROM Countries
WHERE currency = 'EUR'
```

returns the total population of Euro countries. For COUNT, also the argument * is meaningful.

Selection by default returns duplicates if they exist in the tables. Projections, in particular, may produce duplicates:

```
SELECT currency
FROM Countries
```

repeats EUR several times. Duplicates can be removed by the DISTINCT keyword, which also works inside aggregations:

```
SELECT DISTINCT currency

SELECT COUNT(DISTINCT currency)
```

5.4.4 Set operations on queries (UNION, INTERSECT, EXCEPT)

Set operations can be applied to queries, even on the top level. Thus

```
SELECT name, 'big' AS size FROM countries WHERE population >= 50000000
UNION
SELECT name, 'small' AS size FROM countries WHERE population < 50000000
```

shows the populations of countries just as big or small.

NOTE: In one of the course assignments, this trick can be used instead of a CASE expression, which is a "non-relational" way of producing the same effect :-)

UNION, INTERSECT, EXCEPT correspond to the set operations $\cup, \cap, -$ introduced in Chapter 2. Thus they can only be applied to tables "of the same type", i.e. tuples with the same number of elements of the compatible types. The attribute names, however, need not match: it is meaningful to write

```
SELECT capital FROM Countries
UNION
SELECT name FROM Countries
```

5.5 Query usage and semantics: more complex queries

This section covers the part of SQL presented on Lecture 6.

The full form of SELECT queries is, as specified in the grammar,

```
WITH      localdefinitions  -- give names to auxiliary queries
SELECT    attributes
FROM      tables
WHERE     condition
GROUP BY  attributes        -- divide the table to groups
HAVING    condition        -- conditions on the groups
ORDER BY  attributes        -- order the table in a desired way
```

5.5.1 Local definitions (WITH)

Local definitions (WITH clauses) are a simple shorthand mechanism for queries. Thus

```
WITH
  EuroCountries AS (
    SELECT *
    FROM countries
    WHERE currency = 'EuroCountries'
  )
SELECT *
FROM EuroCountries A, EuroCountries B
WHERE ...
```

is a way to avoid the duplication of the query selecting the countries using the Euro as their currency.

5.5.2 Sorting (ORDER BY)

Sorting (ORDER BY) lists a set of attributes considered in lexicographical order. The direction of sorting can be specified for each attribute as DESC or ASC, where ASC is the default. Thus the following query sorts countries primarily by the currency in ascending order, secondarily by size in descending order:

```
SELECT currency, name, population
FROM Countries
ORDER BY currency, population DESC
```

ORDER BY is usually presented as a last field of a SELECT group. But it can also be appended to a query formed by a set-theoretic operation:

```
(SELECT name, 'big' AS size FROM countries WHERE population >= 50000000
 UNION
 SELECT name, 'small' AS size FROM countries WHERE population >= 50000000
 ) ORDER BY size, name
```

shows first all big countries in alphabetical order, then all small ones.

5.5.3 Grouping (GROUP BY) and group conditions (HAVING)

Applying GROUP BY a to a table R forms a new table, where a is the key. For instance, GROUP BY currency forms a table of currencies. But what are the other attributes? The original attributes of R won't do, because each of them may appear many times. For instance, there are many EUR countries. So what is the use of this construction?

The full truth about GROUP BY can be seen only by looking at the SELECT line above it. On this line, only the following attributes of R may appear:

- the grouping attribute a itself
- aggregation functions on the other attributes

In other words, the new relation has these aggregation functions as its non-key attributes. Here is an example:

```
SELECT currency, COUNT(name)
FROM Countries
GROUP BY currency
```

```
currency | count
-----+-----
XCD      |      8
ETB      |      1
HUF      |      1
...
```

Now, most rows in this table will have count 1. We may be interested on only those currencies that are used by more than one country. The standard way of doing this is by a subquery:

```
SELECT *
FROM (
  SELECT currency, COUNT(name) AS number
  FROM Countries
  GROUP BY currency) AS C
WHERE number > 1
```

This shows clearly that GROUP BY really forms a table. But SQL also provides a shorthand way of expressing conditions on the groups (i.e. the rows of the relation formed by GROUP BY): HAVING:

```
SELECT currency, COUNT(name)
FROM Countries
GROUP BY currency
HAVING count(name) > 1
```

If you want to order this from the biggest to the smallest count, just add the line

```
ORDER BY COUNT(name) DESC
```

```
currency | count
-----+-----
EUR      |    35
USD      |    17
XOF      |     8
...
```

The other aggregation functions (SUM, AVG, MAX, MIN) work in the same way. The grouped table can have more than one of them:

```
SELECT currency, COUNT(name), AVG(population)
FROM countries
GROUP BY currency
```

As a final subtlety: the relation formed by GROUP BY also contains the aggregations used in the HAVING clause or the ORDER BY clause:

```
SELECT currency, avg(population)
FROM Countries
GROUP BY currency
HAVING count(name) > 1

SELECT currency, avg(population)
```



```

FROM Countries
GROUP BY currency
ORDER BY count(name) DESC

```

From the semantic point of view, GROUP BY is thus a very complex operator, because one has to look at many different places to see exactly what relation it forms. We will get more clear about this when looking at relational algebra and query compilation in Chapter 7.

5.5.4 Join operations (JOIN)

The syntax of join operations is rich, as there are 24 different join operations:

```

table ::=                -- 24 = 8+8+8
    tablename
    | table jointype JOIN table ON condition      -- 8
    | table jointype JOIN table USING (attribute+) -- 8
    | table NATURAL jointype JOIN table          -- 8

jointype ::=              -- 8 = 6+2
    LEFT|RIGHT|FULL OUTER? -- 6 = 3*2
    | INNER?              -- 2

```

In addition, cartesian product itself is a kind of a join. It is also called CROSS JOIN, but we will use the ordinary notation with commas instead.

Luckily, the JOINS have a compositional meaning. INNER is the simplest join type, and the keyword can be omitted without change of meaning. This JOIN with the ON condition gives the purest form of theta join:

```
FROM table JOIN table ON condition
```

is equivalent to

```
FROM table,table
WHERE condition
```

The condition is typically looking for attributes with equal values in the two tables. With good luck (or design) such attributes have the same name, and one can write

```
L JOIN R USING (a,b)
```

as a shorthand for

```
L JOIN R ON L.a = R.a AND L.b = R.b
```

well... almost, since when JOIN is used with ON, it repeats the values of a and b from both tables, like cartesian product does.

An extreme case is NATURAL JOIN, where no conditions are needed. It is equivalent to

L JOIN R USING (a,b,c,...)

which lists all common attributes of L and R.

Cross join, inner joins, and natural join only include tuples where the join attribute exists in both tables. Outer joins can fill up from either side. Thus left outer join includes all tuples from L, and right outer join from R.

Here are some examples of inner and outer joins:

```
L
a | b
---+---
11 | 21
12 | 22
```

```
R
a | c
---+---
12 | 32
13 | 33
```

```
L cross join R
a | b | a | c
---+---+---+---
11 | 21 | 12 | 32
11 | 21 | 13 | 33
12 | 22 | 12 | 32
12 | 22 | 13 | 33
```

```
L inner join R on L.a = R.a ;
a | b | a | c
---+---+---+---
12 | 22 | 12 | 32
```

```
L natural join R
a | b | c
---+---+---
12 | 22 | 32
```

```
L inner join R using (a)
a | b | c
---+---+---
12 | 22 | 32
```

```
L full outer join R using (a)
a | b | c
---+---+---
```

```

11 | 21 |
12 | 22 | 32
13 |    | 33

```

L left outer join R using (a)

```

a | b | c
-----+-----+-----
11 | 21 |
12 | 22 | 32

```

L right outer join R using (a)

```

a | b | c
-----+-----+-----
12 | 22 | 32
13 |    | 33

```

5.5.5 Pattern matching (LIKE)

The condition `s LIKE p` compares the string `s` with the **pattern** `p`. The pattern can use **wildcards** `_` (for any character) and `%` (for any substring). Thus

```
WHERE name LIKE '%en'
```

is satisfied by all countries whose name ends with "en", e.g. Sweden.

5.6 Views (CREATE VIEW)

A view is like a constant defined in a `WITH` clause, but its definition is global. Views are used for "frequently asked queries". They are built each time from the underlying tables, and hence redundancy is not an issue.

5.7 SQL pitfalls

Here we list some things that do not feel quite logical in SQL design, or whose semantics may feel surprising.

Tables vs. queries

In relational algebra, a query is always an expression for a table (i.e. relation). In SQL, however, there are subtle syntax differences:

- **A bare table name is not a valid query.** A bare `FROM` part is not a valid query either. The shortest way to list all tuples of a table is `SELECT * FROM table`
- Set operations can only combine queries, not table names.
- Join operations can only combine table names, not queries.
- A cartesian product in a `FROM` clause can mix queries and table names, but...

- When a query is used in a FROM clause, it must be given an AS name.
- A WITH clause can only define constants for queries, not for table expressions.

Renaming syntax

Renaming is made with the AS operator, which however has slightly different uses:

- In WITH clauses, the name is before the definition: `name AS (query)`.
- In SELECT parts, the name is after the definition: `expression AS name`.
- In FROM parts, the name is after the definition but may be omitted: `table AS? name`.

Cartesian products

The bare cartesian product from a FROM clause can be a *huge* table, since the sizes are multiplied. With the same logic, if the product contains an empty table, its size is 0 as well. Then it does not matter that the empty table might be "irrelevant":

```
SELECT A.a FROM A, Empty
```

results in an empty table.

NULL values and three-valued logic

Because of NULL values, SQL follows a three-valued logic: TRUE, FALSE, UNKNOWN. The truth tables as such are natural. But the way they are used in e.g WHERE clauses is good to keep in mind. Recalling that a comparison with NULL results in UNKNOWN, and that WHERE clauses only select TRUE instances, the query

```
SELECT ...
FROM ...
WHERE v = v
```

gives no results for tuples where v is NULL. The same concerns

```
SELECT ...
FROM ...
WHERE v < 10 OR v >= 10
```

Hence if v is NULL, it cannot even be assumed that it has the same value in all occurrences.

Another example, given in

<https://www.simple-talk.com/sql/t-sql-programming/ten-common-sql-programming-mistakes/>

as the first one among the "Ten common SQL mistakes", involves NOT IN: if `v` is NULL, then

```
u NOT IN (1,2,v)
```

which means

```
NOT (u = 1 OR u = 2 OR u = v)
```

evaluates in UNKNOWN. Hence it can be useless as a test.

Set operations are set operations

Being a set means that duplicates don't count. This is what holds of relational algebra, but SQL is usually about **multisets**, so that duplicates do count. However, the set operations UNION, INTERSECT, EXCEPT do remove duplicates! Hence

```
SELECT * FROM table
UNION
SELECT * FROM table
```

has the same effect as

```
SELECT DISTINCT * FROM table
```

5.8 SQL in the Query Converter*

The Query Converter has an SQL parser and interpreter, which works much the same way as the PostgreSQL shell. Thus you can give SQL commands in the `qconv` shell, and the database is queried and updated accordingly. You can also see the relational algebra translations of your queries. This is in fact the only reason to use `qconv` as an SQL interpreter rather than PostgreSQL.

Only a part of SQL is currently recognized by `qconv`. The interpreter may moreover be buggy. The database is only built in memory, not stored on a disk. Thus you should store your work in an SQL source file. Such files can be read with the `i` ("import") command, for instance,

```
> i countries.sql
```

which uses the file

<https://github.com/GrammaticalFramework/gf-contrib/blob/master/query-converter/countries.sql>

6 Table modification and triggers

Here we take a deeper look at inserts, updates, and deletions, in the presence of constraints. The integrity constraints of the database may restrict these actions or even prohibit them. An important problem is that when one piece of data is changed, some others may need to be changed as well. For instance, when a row is deleted or updated, how should this affect other rows that reference it as foreign key? Some of these things can be guaranteed by constraints in basic SQL. But some things need more expressive power. For example, when making a bank transfer, money should not only be taken from one account, but the same amount must be added to the other account. For situations like this, DBMSs support **triggers**, which are programs that do many SQL actions at once. The concepts discussed in this chapter are also called **active elements**, because they affect the way in which the database reacts to actions. This is in contrast to the data itself (the rows in the tables), which is "passive".

6.1 Active element hierarchy

Active elements can be defined on different levels, from the most local to the most global:

- **Types** in CREATE TABLE definitions control the atomic values of each attribute without reference to anything else.
- **Inline constraints** in CREATE TABLE definitions also control the atomic values of each attribute, but may refer to some other things.
- **Constraints** in CREATE TABLE definitions control tuples or other sets of attribute, with conditions referring to things inside the table (except for FOREIGN KEY).
- **Assertions**, which are top-level SQL statements, state conditions about the whole database.
- **Triggers**, which are top-level SQL statements, can perform actions on the whole database, using the DBMS.
- **Host program code**, in the embedded SQL case, can perform actions on the whole database, using both the DBMS and the host program.

It is often a good practice to state conditions on as local a level as possible, because they are then available in all wider contexts. However, there are three major exceptions:

- Types such as CHAR(n) may seem to control the length of strings, but they are not as accurate as CHECK constraints. For instance, CHAR(3) only checks the maximum length but not the exact length.
- Inline constraints cannot be changed afterwards by ALTER TABLE. Hence it can be better to use tuple-level named constraints.
- Assertions are disabled in many DBMSs (e.g. PostgreSQL, Oracle) because they can be inefficient. Therefore one should use triggers to mimick assertions. This is what we do in this course.

6.2 Referential constraints and policies

A referential constraint (FOREIGN KEY ... REFERENCES) means that, when a value is used in the referring table, it must exist in the referenced table. But what happens if the value is deleted or changed in the referenced table afterwards? This is what **policies** are for. The possible policies are CASCADE and SET NULL, to override the default behaviour which is to reject the change.

Assume we have a table of bank accounts:

```
CREATE TABLE Accounts (  
    number TEXT PRIMARY KEY,  
    holder TEXT,  
    balance INT  
)
```

Let us then add a table with transfers, with foreign keys referencing the first table:

```
CREATE TABLE Transfers (  
    sender TEXT REFERENCES Accounts(number),  
    recipient TEXT REFERENCES Accounts(number),  
    amount INT  
)
```

What should we do with Transfers if a foreign key disappears i.e. if an account number is removed from Accounts? There are three alternatives:

- (default) reject the deletion from Accounts because of the reference in Transfers,
- CASCADE, i.e. also delete the transfers that reference the deleted account,
- SET NULL, i.e. keep the transfers but set the sender or recipient number to NULL

One of the last two actions can be defined to override the default, but using the following syntax:

```
CREATE TABLE Transfers (  
    sender TEXT REFERENCES Accounts(number)  
        ON UPDATE CASCADE ON DELETE SET NULL,  
    recipient TEXT REFERENCES Accounts(number),  
    amount INT  
)
```

ON UPDATE CASCADE means that if account number is changed in Accounts, it is also changed in Transfers. ON DELETE SET NULL means that if account number is deleted from Accounts, it is changed to NULL in Transfers.

Notice. These policies are probably not the best way to handle accounts and transfers. It probably makes more sense to introduce dates and times, so that rows referring to accounts existing at a certain time need never be changed later.

6.3 CHECK constraints

CHECK constraints, which can be inlined or separate, are like **invariants** in programming. Here is a table definition with two attribute-level constraints, one inlined, the other named and separate:

```
-- specify a format for account numbers: four characters,-, and at least two characters
-- more could be said to limit the characters to digits
CREATE TABLE Accounts (
  number TEXT PRIMARY KEY CHECK (number LIKE '____-%--'),
  holder TEXT,
  balance INT,
  CONSTRAINT positive_balance CHECK (balance >= 0)
)
```

Here we have a table-level constraint referring to two attributes:

```
-- check that money may not be transferred from an account to itself
CREATE TABLE Transfers (
  sender TEXT REFERENCES Accounts(number) ON DELETE SET NULL,
  recipient TEXT REFERENCES Accounts(number),
  amount INT,
  CONSTRAINT not_to_self CHECK (recipient <> sender)
) ;
```

Here is a "constraint" that is not possible in Transfers, trying to say that the balance cannot be exceeded in a transfer:

```
CONSTRAINT too_big_transfer CHECK (amount <= balance)
```

The reason is that the Transfers table cannot refer to the Accounts table (other than in FOREIGN KEY constraints). However, in this case, this is also unnecessary to state: because of the `positive_balance` constraint in Accounts, a transfer exceeding the sender's balance would be automatically blocked.

Here is another "constraints" for Accounts, trying to set a maximum for the money in the bank:

```
CONSTRAINT too_much_money_in_bank CHECK (sum(balance) < 1000000)
```

The problem is that constraints may not use aggregation functions (here, `sum(balance)`), because they are about tuples, not about whole tables. Such a constraint could be stated in an **assertion**, but these are not allowed in PostgreSQL even though they are standard SQL. We will however be able to state this in a trigger, as we will see below.

6.4 ALTER TABLE

A table once created can be changed later with an `ALTER TABLE` statement. The most important ways to alter a table are:

- `ADD COLUMN` with the usual syntax (attribute, type, inline constraints). The new column contains `NULL` values, unless some other default is specified.
- `DROP COLUMN` with the attribute name
- `ADD CONSTRAINT` with the usual constraint syntax. Rejected if the already existing table violates the constraint.
- `DROP CONSTRAINT` with a named constraint

6.5 Triggers

Triggers in PostgreSQL are written in the language PL/PGSQL which is *almost* standard SQL, with an exception:

- the trigger body can only be a function call, and the function is written separately

Here is the part of the syntax that we will need:

```
functiondefinition ::=
    CREATE FUNCTION functionname() RETURNS TRIGGER AS $$
    BEGIN
*   statement
    END
    $$ LANGUAGE 'plpgsql'
    ;

triggerdefinition ::=
    CREATE TRIGGER triggername
        whentriggred
        FOR EACH ROW|STATEMENT
        EXECUTE PROCEDURE functionname
        ;

whentriggred ::=
    BEFORE|AFTER events ON tablename
    | INSTEAD OF  events ON viewname

events ::=
    INSERT | UPDATE | DELETE # can be combined with OR

statement ::=
    IF (condition) THEN statement END IF ;
    | RAISE EXCEPTION 'message' ;
    | sqlstatement ;
```

Comments:

- The statements may refer to NEW.attribute (in case of INSERT and UPDATE) and OLD.attribute (in case of UPDATE and DELETE).
- FOR EACH ROW means that the trigger is executed for each new row affected by an INSERT, UPDATE, or DELETE statement.
- FOR EACH STATEMENT means that the trigger is executed once for the whole statement.
- A trigger is an **atomic transaction**, which either succeeds or fails totally (see Chapter 9 for more details).

Let us consider some examples. The first one is a trigger that update balances in Accounts after each inserted Transfer. In PostgreSQL, we first have to define a function that does the job by CREATE FUNCTION. After that, we create the trigger itself by CREATE TRIGGER.

```
CREATE FUNCTION make_transfer() RETURNS TRIGGER AS $$
BEGIN
    UPDATE Accounts
        SET balance = balance - NEW.amount
        WHERE number = NEW.sender ;
    UPDATE Accounts
        SET balance = balance + NEW.amount
        WHERE number = NEW.recipient ;
END
$$ LANGUAGE 'plpgsql' ;
```

```
CREATE TRIGGER mkTransfer
AFTER INSERT ON Transfers
FOR EACH ROW
EXECUTE PROCEDURE make_transfer() ;
```

The function make_transfer() could also contain checks of conditions, between the BEGIN line and the first UPDATE:

```
IF (NEW.sender = NEW.recipient)
    THEN RAISE EXCEPTION 'cannot transfer to oneself' ;
END IF ;

IF ((SELECT balance FROM Accounts WHERE number = NEW.sender) < NEW.amount)
    THEN RAISE EXCEPTION 'cannot create negative balance' ;
END IF ;
```

”\noindent“ However, both of these things can be already guaranteed by constraints in the affected tables. Then they need not be checked in the trigger. This is clearly better than putting them into triggers, because we could easily forget them!

The second example is limiting the maximum total balance of the bank. This trigger doesn't change anything, and could therefore be defined as an ASSERTION, if they were permitted.

```

CREATE OR REPLACE FUNCTION maxBalance() RETURNS TRIGGER AS $$
BEGIN
    IF ((SELECT sum(balance) FROM Accounts) > 16000)
        THEN RAISE EXCEPTION 'too much money in the bank' ;
    END IF ;
END
$$ LANGUAGE 'plpgsql' ;

```

```

CREATE TRIGGER max_balance
AFTER INSERT OR UPDATE ON Accounts
FOR EACH STATEMENT
EXECUTE PROCEDURE maxBalance() ;

```

The combinations of BEFORE/AFTER, OLD/NEW, and perhaps ROW/STATEMENT are a bit tricky to understand. The best way to understand them is to test different versions in PostgreSQL, monitor effects, and try to understand the error messages.

Triggers can also be defined on views. Then the trigger is executed INSTEAD OF updates, inserts, and deletions.

7 Relational algebra and query compilation

Relational algebra is a mathematical query language. It is much simpler than SQL, as it has only a few operations, each denoted by Greek letters or mathematical symbols. Being so simple, relational algebra is more difficult to use for complex queries than SQL. But for the same reason, it is easier to analyse and optimize. Relational algebra is therefore useful as an intermediate language in a DBMS. SQL queries can be first translated to relational algebra, which is optimized before it is executed. This chapter will tell the basics about this translation and some query optimizations.

7.1 The compiler pipeline

When you write an SQL query in PostgreSQL or some other DBMS, the following things happen:

1. **Lexing:** the query string is analysed into a sequence of words.
2. **Parsing:** the sequence of words is analysed into a **syntax tree**.
3. **Type checking:** the syntax tree is checked for semantic well-formedness, for instance that you are not trying to multiply strings but only numbers, and that the names of tables and attributes actually exist in the database.
4. **Logical query plan generation:** the SQL syntax tree is converted to a **logical query plan**, which is relational algebra expression (actually, its syntax tree).
5. **Optimization:** the relational algebra expression is converted to another relational algebra expression, which is more efficient to execute.
6. **Physical query plan generation:** the optimized relational algebra expression is converted to a **physical query plan**, which is a sequence of algorithm calls.
7. **Query execution:** the physical query plan is executed to produce the result of the query.

We will in this chapter focus on the logical query plan generation. We will also say a few words about optimization, which is perhaps the clearest practical reason for the use of relational algebra.

7.2 Relational algebra

Relational algebra is in principle at least as powerful as SQL as a query language, because all SQL queries can be translated to it. Yet the language is much smaller. Its grammar is shown in Figure 5.

As this is the "official" relational algebra (from the textbook), a couple of SQL constructs cannot however be treated: sorting in `DESC` order and aggregation of `DISTINCT` values. Both of them would be easy to add. More importantly, this language extends the algebra of Chapter 2 in several ways. The most important extension is that it operates on **multisets** (turned to sets by δ, \cup, \cap) and recognizes **order** (controlled by τ).

```

relation ::=
    rename           name of relation (can be used alone)
  |  $\sigma_{\text{condition}}$  relation           selection (sigma) WHERE
  |  $\pi_{\text{projection+}}$  relation           projection (pi) SELECT
  |  $\rho_{\text{rename (attribute+)}}$ ? relation       renaming (rho) AS
  |  $\gamma_{\text{attribute*,aggregationexp+}}$  relation
                                     grouping (gamma) GROUP BY, HAVING
  |  $\tau_{\text{expression+}}$  relation           sorting (tau) ORDER BY
  |  $\delta$  relation           removing duplicates (delta) DISTINCT
  | relation  $\times$  relation   cartesian product FROM, CROSS JOIN
  | relation  $\cup$  relation           union UNION
  | relation  $\cap$  relation           intersection INTERSECT
  | relation  $-$  relation           difference EXCEPT
  | relation  $\bowtie$  relation           NATURAL JOIN
  | relation  $\bowtie_{\text{condition}}$  relation       theta join JOIN ON
  | relation  $\bowtie_{\text{attribute+}}$  relation           INNER JOIN
  | relation  $\bowtie^o_{\text{attribute+}}$  relation           FULL OUTER JOIN
  | relation  $\bowtie^{oL}_{\text{attribute+}}$  relation           LEFT OUTER JOIN
  | relation  $\bowtie^{oR}_{\text{attribute+}}$  relation           RIGHT OUTER JOIN

projection ::=
    expression           expression, can be just an attribute
  | expression  $\rightarrow$  attribute   rename projected expression AS

aggregationexp ::=
    aggregation( *|attribute )           without renaming
  | aggregation( *|attribute )  $\rightarrow$  attribute   with renaming AS

expression, condition, aggregation, attribute as in SQL, Figure 4

```

Figure 5: A grammar of relational algebra. Operator names and other explanations in **boldface**. Corresponding SQL keywords in CAPITAL TYPEWRITER.

7.3 From SQL to relational algebra

The translation from SQL to relational algebra is usually straightforward. It is mostly **compositional** in the sense each SQL construct has a determinate algebra construct that it translates to. For expressions, conditions, aggregations, and attributes, it is trivial, since they need not be changed at all. Figure 5 shows the correspondences as a kind of a dictionary, without exactly specifying how the syntax is translated.

The most problematic cases to deal with are

- grouping expressions
- subqueries in certain positions, e.g. conditions

We will skip subqueries and say more about the grouping expressions. But let us start with the straightforward cases.

7.3.1 Basic queries

As seen in Section 5.4, the most common SQL query form

```
SELECT projections
FROM table,...,table
WHERE condition
```

corresponds to the relational algebra expression

$$\pi_{\text{projections}}\sigma_{\text{condition}}(\text{table} \times \dots \times \text{table})$$

But notice, first of all, that names of relations can themselves be used as algebraic queries. Thus we translate

```
SELECT * FROM Countries
⇒ Countries
SELECT * FROM Countries WHERE name='UK'
⇒  $\sigma_{\text{name='UK'}}$ Countries
```

In general, **SELECT *** does not add anything to the algebra translation. However, there is a subtle exception with grouping queries, to be discussed later.

If the **SELECT** field contains attributes or expressions, these are copied into the same expressions under the π operator. When the field is given another name by **AS**, the arrow symbol is used in algebra:

```
SELECT capital, area/1000 FROM Countries WHERE name='UK'
⇒  $\pi_{\text{capital,area/1000}}\sigma_{\text{name='UK'}}$ Countries
SELECT name AS country, population/area AS density FROM Countries
⇒  $\pi_{\text{name} \rightarrow \text{country}, \text{population/area} \rightarrow \text{density}}$ Countries
```

The renaming of attributes could also be done with the ρ operator:

$\rho_C(\text{country}, \text{density}) \pi_{\text{name}, \text{population}/\text{area}} \text{Countries}$

is a more complicated and, in particular, less compositional solution, because it has to inspect the **SELECT** field for input to two different algebra operations. Moreover, it must invent C as a dummy name for the renamed table. However, ρ is the way to go when names are given to tables in the **FROM** field. This happens in particular when a cartesian product is made with two copies of the same table:

```
SELECT A.name, B.capital
FROM Countries AS A, Countries AS B
WHERE A.name = B.capital
```

\implies

$\pi_{A.\text{name}, B.\text{capital}} \sigma_{A.\text{name} = B.\text{capital}} (\rho_A \text{Countries} \times \rho_B \text{Countries})$

No renaming of attributes takes place in this case.

Set-theoretical operations and joins work in the same way as in SQL. Notice once again that the SQL distinction between "queries" and "tables" is not present in algebra, but everything is relations. This means that all operations work with all kinds of relation arguments, unlike in SQL (see Section 5.7).

7.3.2 Grouping and aggregation

As we saw in Section 5.5.3, **GROUP BY** a (or any sequence of attributes) to a table R forms a new table, where a is the key. The other attributes can be found in two places: the **SELECT** line above and the **HAVING** and **ORDER BY** lines below. All of these attributes must be aggregation function applications.

In relational algebra, the γ operator is an explicit name for this relation, collecting all information in one place. Thus

```
SELECT currency, COUNT(name)
FROM Countries
GROUP BY currency
```

$\implies \gamma_{\text{currency}, \text{COUNT}(\text{name})} \text{Countries}$

```
SELECT currency, AVG(population)
FROM Countries
GROUP BY currency
HAVING COUNT(name) > 1
```

\implies

$\pi_{\text{currency}, \text{AVG}(\text{population})} \sigma_{\text{COUNT}(\text{name}) > 1} \gamma_{\text{currency}, \text{AVG}(\text{population}), \text{COUNT}(\text{name})} \text{Countries}$

Thus the HAVING clause itself becomes an ordinary σ . Notice that, since SELECT does not show the COUNT(name) attribute, a projection must be applied on top.

Here is an example with ORDER BY, which is translated to a τ always applied as the last step:

```
SELECT currency, AVG(population)
FROM Countries
GROUP BY currency
ORDER BY COUNT(name)
```

\implies

$$\tau_{COUNT(name)}\pi_{currency,AVG(population)}\gamma_{currency,AVG(population),COUNT(name)}Countries$$

The "official" version of relational algebra (as in the book) performs the renaming of attributes under SELECT γ itself:

```
SELECT currency, COUNT(name) AS users
FROM Countries
GROUP BY currency
```

\implies

$$\gamma_{currency,COUNT(name)\rightarrow users}Countries$$

However, a more compositional (and to our mind more intuitive) way is do this in a separate π corresponding to the SELECT:

$$\pi_{currency,COUNT(name)\rightarrow users}\gamma_{currency,COUNT(name)}Countries$$

The official notation actually always involves a renaming, even if it is to the aggregation expression to itself:

$$\gamma_{currency,COUNT(name)\rightarrow COUNT(name)}Countries$$

This is of course semantically justified because COUNT(name) on the right of the arrow is not an expression but an attribute (a string without syntactic structure). However, the official notation is not consistent in this, since it does not require corresponding renaming in the π operator.

In addition to GROUP BY, γ must be used whenever an aggregation appears in the SELECT part. This can be understood as grouping by 0 attributes, which means that there is only one group. Thus we translate

```
SELECT COUNT(name) FROM Countries
```

\implies

$$\gamma_{COUNT(name)}Countries$$

We conclude the grouping section with a surprising example:

```

SELECT *
FROM Countries
GROUP BY name
HAVING count(name) > 0

```

Surprisingly, the result is the whole Countries table (because the HAVING condition is always true), without a column for `count(name)`. This may be a bug in PostgreSQL. Otherwise it is a counterexample to the rule that `SELECT *` does not change the relation in any way.

7.3.3 Sorting and duplicate removal

We have already seen a sorting with groupings. Here is a simpler example:

```

SELECT name, capital FROM Countries ORDER BY name

```

$$\implies \tau_{name} \pi_{name, capital} \text{Countries}$$

And here is an example of duplicate removal:

```

SELECT DISTINCT currency FROM Countries

```

$$\implies \delta(\pi_{currency} \text{Countries})$$

(The parentheses are optional.)

7.4 Query optimization

7.4.1 Algebraic laws

Set-theoretic operations obey a large number of laws: associativity, commutativity, idempotence, etc. Many, but not all, of these laws also work for multisets. The laws generate a potentially infinite number of equivalent expressions for a query. Query optimization tries to find the best of those.

7.4.2 Example: pushing conditions in cartesian products

Cartesian products generate huge tables, but only fractions of them usually show up in the final result. How can we avoid building these tables in intermediate stages? One of the most powerful techniques is pushing conditions into products, in accordance with the following equivalence:

$$\sigma_C(R \times S) = \sigma_{C_{rs}}(\sigma_{C_r}R \times \sigma_{C_s}S)$$

where C is a conjunction (AND) of conditions and

- C_r is that part of C where all attributes can be found in R
- C_s is that part of C where all attributes can be found in S
- C_{rs} is the rest of the attributes in C

Here is an example:

```
SELECT * FROM countries, currencies
WHERE code = 'EUR' AND continent = 'EU' AND code = currency
```

Direct translation:

$$\sigma_{code="EUR" \wedge continent="EU" \wedge code=currency}(countries \times currencies)$$

Optimized translation:

$$\sigma_{code=currency}(\sigma_{continent="EU"}countries \times \sigma_{code="EUR"}currencies)$$

7.5 Relational algebra in the Query Converter*

As shown in Section 5.8, `qconv` works as an SQL interpreter. The interpretation is performed via translation to relational algebra close to the textbook style. The notation is actually LaTeX code, and the code shown in these notes is generated with `qconv` (possibly with some post-editing).

The SQL interpreter of `qconv` shows relational algebra expressions in addition to the results. But one can also convert expressions without interpreting them, by the `a` command:

```
> a SELECT * FROM countries WHERE continent = 'EU'
```

The source files are available in

<https://github.com/GrammaticalFramework/gf-contrib/blob/master/query-converter/>

The files of interest are:

- [MinSQL.bnf](#), the grammar of SQL, from which the lexer, parser, and printer are generated,
- [RelAlgebra.bnf](#), the grammar of relational algebra, from which the lexer, parser, and printer are generated,
- [SQLCompiler.hs](#), the translator from SQL to relational algebra,
- [Algebra.hs](#), the conversion of logical to algorithmic ("physical") query plans,
- [Relation.hs](#), the code for executing the physical query plans,
- [OptimizeAlgebra.hs](#), some optimizations of relational algebra.

8 SQL in software applications

End user programs are often built by combining SQL and a general purpose programming language. This is called **embedding**, and the general purpose language is called a **host language**. In this lecture, we look at how SQL is embedded in Java. We will also cover some pitfalls in embedding. For instance **SQL injection** is a security hole where an end user can include SQL code in the data that she is asked to give. In one famous example, the name of a student includes a piece of code that deletes all data from a student database. To round off, we will look at the highest level of database access from the human point of view: natural language queries.

8.1 SQL as a part of a bigger program

SQL was once meant to be a high-level query language, easy to learn for non-programmers. However, direct access to SQL (e.g. via the PostgreSQL shell) can be both too demanding and too powerful. Most database access by end users hence takes place via more high-level interfaces such as web forms. People use them for doing bank transfers and booking train tickets. Then the host language in which SQL is embedded provides GUIs and other means that makes data access easier. Database are also accessed by programs that analyse them, for instance to collect statistics. Then the host language provides computation methods that are more powerful than those available in SQL.

8.2 A minimal JDBC program*

Java is a verbose language, and accessing a database is just one of the cases that requires a lot of wrapper code. Figure 6 is the smallest complete program we could figure out that does something meaningful. The user writes a country name and the program returns the capital. After this, a new prompt for a query is displayed. For example:

```
> Sweden
Stockholm
>
```

The program is very rough in the sense that it does not even recover from errors or terminate gracefully. Thus the only way to terminate it is by "control-C". A more decent program is shown in the course material (Assignment 5) - a template from which Figure 6 is a stripped-down version.

The SQL-specific lines are marked *.

- The first one loads the `java.sql` JDBC functionalities.
- The second one, in the `main` method, loads a PostgreSQL driver class.
- The next three ones define the database url, username, and password.
- Then the connection is opened by these parameters. The rest of the `main` method is setting the user inaction loop as a "console".

```

import java.sql.*; // JDBC functionalities *
import java.io.*; // Reading user input

public class Capital
{
    public static void main(String[] args) throws Exception
    {
        Class.forName("org.postgresql.Driver") ; // load the driver class *

        String url = "jdbc:postgresql://ate.ita.chalmers.se/" ; // database url *
        String username = "tda357_XXX" ; // your username *
        String password = "XXXXXX" ; // your password *

        Connection conn = DriverManager.getConnection(url, username, password); //connect to db *

        Console console = System.console(); // create console for interaction
        while(true) { // loop forever
            String country = console.readLine("> ") ; // print > as prompt and read query
            getCapital(conn, country) ; // execute the query
        }
    }

    static void getCapital(Connection conn, String country) throws SQLException // *
    {
        Statement st = conn.createStatement(); // start new statement *
        ResultSet rs = // get the query results *
            st.executeQuery("SELECT capital FROM Countries WHERE name = '" + country + "'") ; *
        while (rs.next()) // loop through all results *
            System.out.println(rs.getString(2)) ; // print column 2 with newline *

        rs.close(); // get ready for new query *
        st.close(); // get ready for new statement *
    }
}

```

Figure 6: A minimal JDBC program, answering questions "what is the capital of this country". It prints a prompt > , reads a country name, prints its capital, and waits for the next query. It does not yet quit nicely or catch exceptions properly. The SQL-specific lines are marked with *.

- The method `getCapital` that sends a query and displays the results can **throw** an exception (a better method would **catch** it). This exception happens for instance when the SQL query has a syntax error.
- The actual work takes place in the body of `getCapital`:
 - The first thing is to create a `Statement` object, which has a method for executing a query.
 - Executing the query returns a `ResultSet`, which is an iterator for all the results.
 - We iterate through the rows with a while loop on `rs.next()`, which returns `False` when all rows have been scanned.
 - For each row, we print column 2, which holds the capital.
 - The `ResultSet` object `rs` enables us to `getString` for the column.
 - At the end, we close the result set `rs` and the statement `st` nicely to get ready for the next query.

The rest of the code is ordinary Java. For the database-specific parts, excellent Javadoc documentation can be found for googling for the APIs with class and method names. The only tricky thing is perhaps the concepts `Connection`, `Statement`, and `ResultSet`:

- A **connection** is opened just in the beginning, with URL, username, and password. This is much like starting the `psql` program in a Unix shell.
- A **statement** is opened once for any SQL statement to be executed, be it a query or an update, and insert, or a delete.
- A **result set** is obtained when a query is executed. Other statements don't return result sets, but just modify the database.

It is important to know that the result set is overwritten by each query, so you cannot collect many of them without "saving" them e.g. with for loops.

8.3 Building queries and updates from input data*

When building a query, it is obviously important to get the spaces and quotes in right positions! A safer way to build a query is to use a **prepared statement**. It has question marks for the arguments to be inserted, so we don't need to care about spaces and quotes. But we do need to select the type of each argument, with `setString(Arg,Val)`, `setInt(Arg,Val)`, etc.

```
static void getCapital(Connection conn, String country) throws SQLException
{
    PreparedStatement st =
        conn.prepareStatement("SELECT capital FROM Countries WHERE name = ?") ;
    st.setString(1, country) ;
    ResultSet rs = st.executeQuery() ;
    if (rs.next())
        System.out.println(rs.getString(1)) ;
    rs.close() ;
    st.close() ;
}
```

Modifications - inserts, updates, and deletes - are made with statements in a similar way as queries. In JDBC, they are all called **updates**. A **Statement** is needed for them as well. Here is an example of registering a mountain with its name, continent, and height.

```
// user input example: Kebnekaise Europe 2111

static void addMountain(Connection conn, String name, String continent, String height)
    throws SQLException
{
    PreparedStatement st =
        conn.prepareStatement("INSERT INTO Mountains VALUES (?, ?, ?)" );
    st.setString(1, name) ;
    st.setString(2, continent) ;
    st.setInt(3, Integer.parseInt(height)) ;
    st.executeUpdate() ;
    st.close() ;
}
```

Now, how to divide the work between SQL and Java? As a guiding principle,

Put as much of your program in the SQL query as possible.

In a more complex program (as we will see shortly), one can send several queries and collect their results from result sets, then combine the answer with some Java programming. But this is not using SQL's capacity to the full:

- You miss the optimizations that SQL provides, and have to reinvent them manually in your code.
- You increase the network traffic.

Just think about the "pushing conditions" example from Section 7.4.2.

```
SELECT * FROM countries, currencies
WHERE code = 'EUR' AND continent = 'EU' AND code = currency
```

If you just query the first line with SQL and do the WHERE part in Java, you may have to transfer thousands of times of more rows that you moreover have to inspect than when doing everything in SQL.

8.4 SQL injection

An SQL injection is a hostile attack where the input data contains SQL statements. Such injections are possible if input data is pasted with SQL parts in a simple-minded way. Here are two examples, modified from

<https://www.owasp.org/index.php/SQL-Injection>

which is an excellent source on security attacks in general, and how to prevent them.

The first injection is in a system where you can ask information about yourself by entering your name. If you enter the name **John**, it builds and executes the query

```
SELECT * FROM Persons
WHERE name = 'John'
```

If you enter the name **John' OR 0=0--** it builds the query

```
SELECT * FROM Persons
WHERE name = 'John' OR 0=0--'
```

which shows all information about all users!

One can also change information by SQL injection. If you enter the name "John";DROP TABLE Persons- it builds the statements

```
SELECT * FROM Persons
WHERE name = 'John';
```

```
DROP TABLE Persons--'
```

which deletes all person information.

Now, if you use JDBC, the latter injection is not so easy, because you cannot execute modifications with `executeQuery()`. But you can do the such a thing if the statement asks you to insert your name.

A better help prpvded by JDBC is to use `preparedStatement` with ? variables instead of pasting in strings with Java's +. The implementation of `preparedStatement` performs a proper **quoting** of the values. Thus the first example becomes rather like

```
SELECT * FROM Persons
WHERE name = 'John'' OR 0=0;--'
```

where the first single quote is escaped and the whole sting is hence included in the name.

8.5 The ultimate query language?*

SQL was once meant to be a high-level query language, easy to learn for non-programmers. In some respects, it is like COBOL: very verbose with English-like keywords, and a syntax that with good luck reads like English sentences: *select names from countries where the continent is Europe*. Real natural language queries of course have a richer syntax and may require effort from the compiler to execute. Here are some examples of syntactic forms easily interpretable in SQL:

```
what is the capital of Sweden
SELECT capital FROM countries WHERE name='Sweden'
```

```
which countries have EUR as currency
SELECT name FROM Countries WHERE currency='EUR'
```

```
which countries have a population under 1000000
SELECT name FROM Countries WHERE population<1000000
```

```
how many countries have a population under 1000000
SELECT count(*) FROM Countries WHERE population<1000000
```

```
show everything about all countries where the population is under 1000000
SELECT * FROM Countries WHERE population<1000000
```

```
show the country names and currency names for all countries and currencies
```

```
such that the continent is Europe and currency is the currency code
SELECT Countries.name, Currencies.name FROM Countries, Currencies
WHERE continent='Europe' AND currency=Currencies.code
```

It is possible to write grammars that analyse these queries and translate them to SQL, just like and SQL compiler translates SQL queries to relational algebra. This was in fact a popular topic in the 1970's and 1980's, after the successful LUNAR system for querying about moon stones:

<http://web.stanford.edu/class/linguist289/woods.pdf>

Natural language question answering is becoming popular again, in systems like Wolfram Alpha and IBM Watson. They are expected to give

- more fine-grained search possibilities than plain string-based search
 - support for queries in speech, like in Google's Voice Search and Apple's Siri.
- The main problems of natural language search are
- precision: without a grammar comparable to e.g. SQL grammar, it is difficult to interpret complex queries correctly
 - coverage: queries can be expressed in so many different ways that it is difficult to have a complete grammar
 - ambiguity: a query can have different interpretations, which is sometimes clear from context (but exactly how?), sometime not:
 - *Please tell us quickly, Intelligent Defence System: Are the missiles coming across the ocean or over the North Pole?*
 - Calculating..... Yes.

Interestingly, once we can solve these problems for one language, other languages follow the same patterns:

```
vad är Sveriges huvudstad
vilka länder har EUR som valuta
vilka länder har en befolkning under 1000000
hur många länder har en befolkning under 1000000
visa allt om alla länder där befolkningen är under 1000000
visa landnamnen och valutnamnen för alla länder och valutor
där kontinenten är Europa och valutan är valutakoden
```

Natural language queries are in the intersection of database technology and artificial intelligence. The problem can be approached incrementally, by accumulating technology and knowledge. Much of the research is on collecting the knowledge automatically, by for instance using machine learning. This is the case in particular when the knowledge is in unstructured form such as text. However, when the knowledge is already in a database, the question becomes much more like query compilation.

9 Remaining SQL topics: transactions, authorization, indexes

Repeating what was said before: SQL is a huge language, and the course does not cover all of it. This last SQL lecture is a "smörgåsbord" of things that have not been covered before. They are not covered in the course assignments either, but they may appear in the exam. Each of the topics moreover has some theoretical interest. Thus **transactions** are related to **concurrency**, where simultaneous database accesses by different users may create inconsistencies. **Authorization** is a systematic view to the rights (read, write, etc) that different users can be given. **Indexes** are a way to make queries faster, at the cost of some space and slower updates. These concepts are introduced together with ways of reasoning about the corresponding problems.

9.1 Authorization and grant diagrams

When a user creates an SQL object (table, view, trigger, function), she becomes the **owner** of the object. She can **grant privileges** to other users, and also **revoke** them. Here is the SQL syntax for this:

```
statement ::=
    GRANT privilege+ ON object TO user+ grantoption?
  | REVOKE privilege+ ON object FROM user+ CASCADE?
  | REVOKE GRANT OPTION FOR privilege ON object FROM user+ CASCADE?
  | GRANT rolename TO username adminoption?

privilege ::=
    SELECT | INSERT | DELETE | UPDATE | REFERENCES | ...
  | ALL PRIVILEGES

object ::=
    tablename (attribute)+ | viewname (attribute)+ | trigger | ...

user ::= username | rolename | PUBLIC

grantoption ::= WITH GRANT OPTION

adminoption ::= WITH ADMIN OPTION
```

Chains of granted privileges give rise to **grant diagrams**, which ultimately lead to the owner. Each node consists of a username, privilege, and a tag for ownership (**) or grant option (*). Granting a privilege creates a new node, with an arrow from the granting privilege.

A user who has granted privileges can also revoke them. The CASCADE option makes this affect all the nodes that are reachable only via the revoked privilege. The default is RESTRICT, which means that a REVOKE that would affect other nodes is rejected.

Figure 7 shows an example of a grant diagram and its evolution.

Users can be collected to **roles**, which can be granted and revoked privileges together. The SQL privileges can be compared with the privileges in the Unix

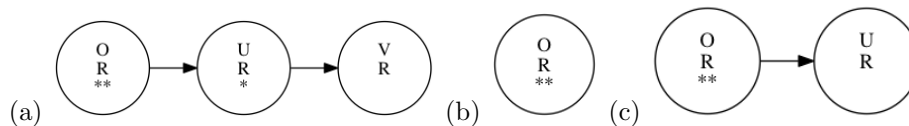

Figure 7: Grant diagrams, resulting from: (a) O: GRANT R TO U WITH GRANT OPTION ; U: GRANT p TO V (b) (a) followed by O: REVOKE R FROM U (c) (a) followed by O: REVOKE GRANT OPTION FOR R FROM U

file system, where

- privileges are "read", "write", and "execute"
- objects are files and directories
- roles are groups

The main difference is that the privileges and objects in SQL are more fine-grained.

Example. What privileges are needed for the following? TODO

9.2 Transactions

A **transaction** is a sequence of statements that is executed together. A transaction succeeds or fails as a whole. For instance, a bank transfer can consist of two updates, collected to a transaction:

```
BEGIN ;
UPDATE Accounts
  SET (balance = balance - 100) WHERE holder = 'Alice' ;
UPDATE Accounts
  SET (balance = balance + 100) WHERE holder = 'Bob' ;
COMMIT ;
```

If the first update fails, for instance, because Alice has less than 100 pounds, the whole transaction fails. We can also manually interrupt a transaction by a ROLLBACK statement.

Individual SQL statements are automatically transactions. This includes the execution of triggers, which we used for bank transfers in Chapter 6. Otherwise, transactions can be created by grouping statements between BEGIN and COMMIT.

Transactions are expected to have so-called **ACID properties**:

- A, **Atomicity**: the transaction is an atomic unit that succeeds or fails as a whole.
- C, **Consistency**: the transaction keeps the database consistent (i.e. preserves its constraints).
- I, **Isolation**: parallel transactions operate independently of each other.
- D, **Durability**: committed transactions have persistent effect even if the system has a failure.

Hint. The main purpose of transactions is to keep the data consistent. But a transaction can also be faster than individual statements. For instance, if you

want to execute thousands of `INSERT` statements, it can be better to make them into one transaction.

The full syntax of starting transactions is as follows:

```
statement ::=
    START TRANSACTION mode* | BEGIN | COMMIT | ROLLBACK

mode ::=
    ISOLATION LEVEL level
    | READ WRITE | READ ONLY | NOT? DEFERRABLE

level ::=
    SERIALIZABLE | REPEATABLE READ | READ COMMITTED | READ UNCOMMITTED
```

The `READ WRITE` and `READ ONLY` modes indicate what **interferences** are possible. The `DEFERRABLE` mode means that constraints that are defined as `DEFERRABLE` in `CREATE TABLE` statements are only checked at the end of the transaction.

9.3 Interferences and isolation levels

Sometimes ACID properties are too rigid. For instance, the I (Isolation) property may prevent parallel transactions from proceeding at all, if any of them is `READ WRITE`. This condition can be weakened by using **isolation levels**. These levels are defined as follows:

- **SERIALIZABLE**: the transaction only sees data that was committed before the transaction began.
- **REPEATABLE READ**: like `READ COMMITTED`, but previously read data may not be changed.
- **READ COMMITTED**: the transaction can see data that is committed by other transactions during it is running, in addition to data committed before it started.
- **READ UNCOMMITTED**: the transaction sees everything from other transactions, even uncommitted.

The standard example about parallel transactions is flight booking. Suppose you have the schema

```
Seats(date,flight,seat,status)
```

where the `status` is either "vacant" or occupied by a passenger. Now, an internet booking program may inspect this table to suggest flights to customers. After the customer has chosen a seat, the system will update the table:

```
SELECT seat FROM Seats WHERE status='vacant' AND date=...
UPDATE Seats SET status='occupied' WHERE seat=...
```

It makes sense to make this as one transaction.

However, if many customers want the same flight on the same day, how should the system behave? The safest policy is only to allow one booking transaction at a time and let all others wait. This would guarantee the ACID properties. The opposite is to let SELECTs and UPDATEs be freely intertwined. This could lead to **interference problems** of the following kinds:

- **Dirty reads:** read data resulting from a concurrent uncommitted transaction.

```
T1 _____READ a _____
T2 _____INSERT a _____ROLLBACK____
```

- **Non-repeatable reads:** read data twice and get different results (because of concurrent committed transaction that modifies or deletes the data).

```
T1 _____READ a _____READ a
T2 _____UPDATE a=a'____COMMIT _____
```

- **Phantoms:** execute a query twice and get different results (because of concurrent committed transaction).

```
T1 SELECT * FROM A _____SELECT * FROM A
T2 _____INSERT INTO A a____COMMIT _____
```

The following table shows which interference are allowed by which isolation levels, from the strictest to the loosest:

	dirty reads	non-repeatable reads	phantoms
SERIALIZABLE	-	-	-
REPEATABLE READ	-	-	+
READ COMMITTED	-	+	+
READ UNCOMMITTED	+	+	+

Note. PostgreSQL has only three distinct levels: SERIALIZABLE, REPEATABLE READ, and READ COMMITTED. READ UNCOMMITTED means READ COMMITTED. Hence no dirty reads are allowed.

9.4 Indexes

An index is an efficient lookup table, making it fast to fetch information. A DBMS automatically creates an index for the primary key of each table. One can manually create and drop keys for other attributes by using the following SQL syntax:

```
statement ::=
    CREATE INDEX indexname ON tablename (attribute+)?
    | DROP INDEX indexname
```

Creating an index is a mixed blessing, since it

- speeds up queries
- makes modifications slower

An index obviously also takes extra space. To decide whether to create an index on some attributes, one should estimate the **cost** of typical operations. The cost is traditionally calculated by the following **cost model**:

- The **disk** is divided to **blocks**.
- Each tuple is in a block, which may contain many tuples.
- A **block access** is the smallest unit of time.
- Read 1 tuple = 1 block access.
- Modify 1 tuple = 2 block accesses (read + write).
- Every table is stored in some number n blocks. Hence,
 - Reading all tuples of a table = n block accesses.
 - In particular, lookup all tuples matching an attribute without index = n .
 - Similarly, modification without index = $2n$
 - Insert new value without index = 2 (read one block and write it back)
- An index is stored in 1 block (idealizing assumption). Hence, for indexed attributes,
 - Reading the whole index = 1 block access.
 - Lookup 1 tuple (i.e. to find where it is stored) = 1 block access
 - Fetch all tuples = $1 + k$ block accesses (where $k \ll n$ is the number of tuples per attribute)
 - In particular, fetching a tuple if the index is a key = 2 ($1 + k$ with $k=1$)
 - Modify (or insert) 1 tuple with index = 4 block accesses (read and write both the tuple and the index)

With this model, the decision goes as follows:

1. Generate some candidates for indexes: I_1, \dots, I_k
2. Identify the a set of typical SQL statements (for instance, the queries and updates performed via the end user interface): S_1, \dots, S_n
3. For each candidate index configuration, compute the costs of the typical statements: $C(I_i, S_j)$
4. Estimate the probabilities of each typical statement, e.g. as its relative frequency: $P(S_j)$
5. Select the best index configuration, i.e. the one with the lowest expected cost: $\text{argmin}_i \sum_{j=1}^n P(S_j)C(I_i)$

Example. Consider a phone book, with the schema

`PhoneNumbers (name, number)`

Neither the name nor the number can be assumed to be a key, since one person can have many numbers, and many persons can share a number. Assume that

- the table is stored in 100 blocks: $n=100$
- each name has on the average 2 numbers ($k=2$), whereas each number has 1 person ($k=1$; actually, 1.01, but we round this down to 1)

- the following statement types occur with the following frequencies:

```

SELECT number FROM PhoneNumbers WHERE name=X -- 0.8
SELECT name FROM PhoneNumbers WHERE number=Y -- 0.05
INSERT INTO PhoneNumbers VALUES (X,Y) -- 0.15

```

Here are the costs with each indexing configuration, with "index both" as the winner:

	no index	index name	index number	index both
SELECT number	100	3	100	3
SELECT name	100	100	2	2
INSERT	2	4	4	6
total cost	85.3	8.0	80.25	3.0
why	80+5+0.3	2.4+5+0.6	80+0.05+0.2	2.4+0.1+0.9

10 Alternative data models

The relational data model has been dominating the database world for a long time. But there are alternative models, some of which are gaining popularity. XML is an old model, often seen as a language for documents rather than data. In this perspective, it is a generalization of HTML. But it is a very powerful generalization, which can be used for any structured data. XML data objects need not be just tuples, but they can be arbitrary trees. XML also has designated query languages, such as XPath and XQuery. This chapter introduces XML and gives a summary of XPath. On the other end of the scale, there are models simpler than SQL, known as "NoSQL" models. These models are popular in so-called big data applications, since they support the distribution of data on many computers. NoSQL is implemented in systems like Cassandra, originally developed by Facebook and now also used for instance by Spotify.

10.1 XML and its data model

XML (**eXtensible Markup Language**) is a notation for documents and data. For documents, it can be seen as a generalization of HTML (Hypertext Markup Language): HTML is just one of the languages that can be defined in XML. If more structure is wanted for special kinds of documents, HTML can be "extended" with the help of XML. For instance, if we want to store an English-Swedish dictionary, we can build the following kind of XML objects:

```
<word>
  <pos>Noun</pos>
  <english>computer</english>
  <swedish>dator</swedish>
</word>
```

(where pos = part of speech = "ordklass"). When printing the dictionary, this object could be transformed into an HTML object,

```
<p>
  <i>computer</i> (Noun)
  dator
</p>
```

But the HTML format is of course less suitable for using the dictionary as *data*, where one can look up words. Therefore the original XML structure is better suited for storing the dictionary data.

The form of an XML data object is

```
<tag> ... </tag>
```

where `<tag>` is the **start tag** and `</tag>` is the **end tag**. A limiting case is tags without no content in between, which has a shorthand notation,

`<tag/> = <tag></tag>`

All XML data must be properly nested between start and end tags. The syntax is the same for all kinds of XML, including XHTML (which is XML-compliant HTML): Plain HTML, in contrast to XHTML, also allows start tags without end tags.

From the data perspective, the XML object corresponds to a row in a relational database with the schema

`Words(pos,english,swedish)`

A schema for XML data can be defined in a DTD (**Document Type Declaration**). The DTD expression for the "word" schema assumed by the above object is

```
<!ELEMENT word (pos, english, swedish)>
<!ELEMENT pos (#PCDATA)>
<!ELEMENT english (#PCDATA)>
<!ELEMENT swedish (#PCDATA)>
```

The entries in a DTD define **elements**, which are structures of data. The first line defines an element called `word` as a tuple of elements `pos`, `english`, and `swedish`. These other elements are all defined as `#PCDATA`, which means **parsed character data**. It can be used for translating `TEXT` in SQL. But it is moreover *parsed*, which means that all XML tags in the data (such as HTML formatting) are interpreted as tags. (There is also a type for unparsed text, `CDATA`, but it cannot be used in `ELEMENT` declarations.)

XML supports more data structures than the relational model. In the relational model, the only structure is the tuple, and all its elements must be atomic. In full XML, the elements of tuples can be structured elements themselves. They are called **daughter elements**. In fact, XML supports **algebraic datatypes** similar to Haskell's `data` definitions:

- Elements can be defined as

tuples of elements:	<code>E, F</code>
lists of elements:	<code>E*</code>
nonempty lists of elements:	<code>E+</code>
alternative elements:	<code>E F</code>
optional elements:	<code>E?</code>
strings:	<code>#PCDATA</code>

- Elements can be **recursive**, that is, a part of an element can be an instance of the element itself. This enables elements of unlimited size.
- Thus the elements of XML are **trees**, not just tuples. (A tuple is a limiting case, with just one branching node and leaves under it.)

The **validation** of an XML document checks its correctness with respect to a DTD. It corresponds to type checking in Haskell. Validation tools are available on the web, for instance, <http://validator.w3.org/>

Figure 8 gives an example of a recursive type. It encodes a data type for arithmetic expression, and an element representing the expression $23 + 15 * x$. It shows a complete XML document, which consists of a header, a DTD (starting with the keyword `DOCTYPE`), and an element. It also shows a corresponding algebraic datatype definition in Haskell and a Haskell expression corresponding to the XML element.

To encode SQL tuples, we only need the tuple type and the `PCDATA` type. However, this DTD encoding does not capture all parts of SQL's table definitions:

- basic types in XML are not so refined: basically only `TEXT` is available
- constraints cannot be expressed in the DTD

Some of these problems can be solved by using **attributes** rather than elements. Here is an alternative representation of dictionary entries:

```
<!ELEMENT word EMPTY>
<!ATTLIST word
  pos CDATA #REQUIRED
  english CDATA #REQUIRED
  swedish CDATA #REQUIRED
>
<word pos="Noun" english="Computer" swedish="Dator">
```

The `#REQUIRED` keyword is similar to a `NOT NULL` constraint in SQL. Optional attributes have the keyword `#IMPLIED`.

Let us look at another example, which shows how to model referential constraints:

```
<!ELEMENT Country EMPTY>
<!ATTLIST Country
  name CDATA #REQUIRED
  currency IDREF #REQUIRED
>
<!ELEMENT Currency EMPTY>
<!ATTLIST Currency
  code ID #REQUIRED
  name CDATA #REQUIRED
>
```

The `code` attribute of `Currency` is declared as `ID`, which means that it is an identifier (which moreover has to be unique). The `currency` attribute of `Country` is declared as `IDREF`, which means it must be an identifier declared as `ID` in some other element. However, since `IDREF` does not specify *what* element, it only comes half way in expressing a referential constraint. Some of these problems are solved in alternative format to DTD, called **XML Schema**.

```

-- XML

<?xml version="1.0" encoding="utf-8" standalone="no"?>
<!DOCTYPE expression [
  <!ELEMENT expression (variable | constant | addition | multiplication)>
  <!ELEMENT variable (#PCDATA)>
  <!ELEMENT constant (#PCDATA)>
  <!ELEMENT addition (expression,expression)>
  <!ELEMENT multiplication (expression,expression)>
]>

<expression>
  <addition>
    <expression>
      <constant>23</constant>
    </expression>
    <expression>
      <multiplication>
        <expression>
          <constant>15</constant>
        </expression>
        <expression>
          <variable>x</variable>
        </expression>
      </multiplication>
    </expression>
  </addition>
</expression>

-- Haskell

data Expression =
  Variable String
  | Constant String
  | Addition Expression Expression
  | Multiplication Expression Expression

Addition
  (Constant "23")
  (Multiplication
    (Constant "15")
    (Variable "x"))

```

Figure 8: A complete XML document for arithmetic expressions and the corresponding Haskell code.

Attributes were originally meant for metadata (such as font size) rather than data. In fact, the recommendation from W3C is to use elements rather than attributes for data (see http://www.w3schools.com/xml/xml_dtd_el_vs_attr.asp). However, since attributes enable some constraints that elements don't, their use for data can be justified.

10.2 The XPath query language

The XPath language gives a concise notation to extract XML elements. Its syntax is quite similar to Unix directory paths. Here is a grammar for a part of XPath:

```
xpath ::=
    axis item condition? xpath # continue with any xpath
  | xpath | xpath             # union of xpaths, with literal "|"
  |                           # end of xpath

axis ::=
  | /           # this level
  | //          # any level below

item ::=
  | element
  | @attribute
  | *           # any element
  | @*         # any attribute
  | ..         # level above

condition ::=
  [ expression =|!= expression ]

expression ::=
  @attribute | integer | string
```

Here are some examples: - /Countries/country all <country> elements right under <Countries> - /Countries//@name all values of name attribute anywhere under <Countries> - /Countries/currency/[@name = "dollar"] all <currency> elements where name is dollar

There is a more expressive query language called **XQuery**, which extends XPath. Another possibility is to use **XSLT** (eXtensible Stylesheet Language for Transformations), whose standard use is to convert between XML formats (e.g. from dictionary data to HTML). Writing queries in a host language (in a similar way as in JDBC) is of course also a possibility.

There is an on-line XPath test program in <http://xmlgrid.net/xpath.html> but I didn't manage to make it work yet.

10.3 XML and XPath in the query converter

The Query Converter has a functionality for converting an SQL database into an XML object, with its schema as DTD. It also implements a part of the XPath query language. The command

```
x
```

without an argument prints the current database as an XML document (with DTD and the elements). The command `xp` takes an XPath query as an argument and shows the result of executing it:

```
xp /QConvData//@name
```

extracts all values of the `name` attribute everywhere in the descendants of `/QConvData`. (At the time of writing, the XPath interpreter is not fully functional.)

The XML encoding of SQL tuples uses attributes rather than child elements. It does not (yet) express the `IDREF` constraints. All tables are wrapped in an element called `QConvData`.

The command

```
ix <FILE>
```

reads an XML file, parses it, and validates it if it has a DTD. The `xp` command with an XPath query applies to all XML files that have been read either in this way or by conversion from SQL. Hence one can also query XML databases that are not representable as SQL.

10.4 NoSQL data models*

Big Data is a word used for data whose mere size is a problem. What the size is depends on many things, such as available storage and computing power. At the time of writing, Big Data is often expected to be at least terabytes (10^{12} bytes), maybe even petabytes (10^{15}).

In relational databases, each table must usually reside in one computer. In Big Data, data is usually **distributed**, maybe to thousands of computers (or millions in the case of companies like Google). The computations must also be **parallelizable** as much as possible. This has implications for big data systems, which makes them different from relational databases:

- simpler queries (e.g. no joins, search on indexed attributes only)
- looser structures (e.g. no tables with rigid schemas)
- less integrity guarantees (e.g. no checking of constraints, no transactions)
- more redundancy ("denormalization" to keep together data that belongs together)

NoSQL is not just one data model but several:

- key-value model
- column-oriented model
- graph model

We will take a closer look at Cassandra, which is a hybrid of the first two

10.5 The Cassandra DBMS and its query language CQL*

”Cassandra is essentially a hybrid between a key-value and a column-oriented (or tabular) database. Its data model is a partitioned row store with tunable consistency... Rows are organized into tables; the first component of a table’s primary key is the partition key; within a partition, rows are clustered by the remaining columns of the key... Other columns may be indexed separately from the primary key.”

https://en.wikipedia.org/wiki/Apache_Cassandra

Here is a comparison between Cassandra and relational databases:

	Cassandra	SQL
data object	key-value pair=(rowkey, columns)	row
single value	column=(attribute,value,timestamp)	column value
collection	column family	table
database	keyspace	schema, E-R diagram
storage unit	key-value pair	table
query language	CQL	SQL
query engine	MapReduce	relational algebra

The **MapReduce** query engine is similar to `map` and `fold` in functional programming. The computations can be made in parallel in different computers. It was originally developed at Google, on top of the **Bigtable** data storage system. Bigtable is a proprietary system, which was the model of the open-source Cassandra, together with Amazon’s **Dynamo** data storage system.² The MapReduce implementation used by Cassandra is **Hadoop**.

It is easy to try out Cassandra, if you are familiar with SQL. Let us follow the instructions from the tutorial in

<https://wiki.apache.org/cassandra/GettingStarted>

Step 1. Download Cassandra from <http://cassandra.apache.org/download/>

Step 2. Install Cassandra by unpacking the downloaded archive.

Step 3. Start Cassandra server by going to the created directory and giving the command

```
bin/cassandra -f
```

Step 4. Start CQL shell by giving the command

```
bin/cqlsh
```

The following CQL session shows some of the main commands. First time you have to create a keyspace:

```
cqlsh> CREATE KEYSPACE mykeyspace
WITH REPLICATION = { 'class' : 'SimpleStrategy', 'replication_factor' : 1 };
```

² The distribution and replication of data in Cassandra is more like in Dynamo.

Take it to use for your subsequent commands:

```
cqlsh> USE mykeyspace ;
```

Create a column family - in later versions kindly called a "table"!

```
> CREATE TABLE Countries (  
    name TEXT PRIMARY KEY,  
    capital TEXT,  
    population INT,  
    area INT,  
    currency TEXT  
);
```

Insert values for different subsets of the columns:

```
> INSERT INTO Countries  
    (name,capital,population,area,currency)  
    VALUES ('Sweden','Stockholm',9000000,444000) ;
```

```
> INSERT INTO Countries  
    (name,capital)  
    VALUES ('Norway','Oslo') ;
```

Make your first queries:

```
> SELECT * FROM countries ;
```

name	area	capital	currency	population
Sweden	444000	Stockholm	SEK	9000000
Norway	null	Oslo	null	null

```
> SELECT capital, currency FROM Countries WHERE name = 'Sweden' ;
```

capital	currency
Stockholm	SEK

Now you may have the illusion of being in SQL! However,

```
> SELECT name FROM Countries WHERE capital = 'Oslo' ;
```

```
InvalidRequest: code=2200 [Invalid query] message=
```

```
"No secondary indexes on the restricted columns support the provided operators: "
```

So you can only retrieve indexed values. PRIMARY KEY creates the primary index, but you can also create a **secondary index**:

```
> CREATE INDEX on Countries(capital) ;
> SELECT name FROM Countries WHERE capital = 'Oslo' ;
```

```
name
-----
Norway
```

Most SQL constraints have no counterparts, but PRIMARY KEY does:

```
> INSERT INTO countries
  (capital,population,area,currency)
  VALUES ('Helsinki',5000000, 337000,'EUR') ;
```

```
InvalidRequest: code=2200 [Invalid query] message=
"Missing mandatory PRIMARY KEY part name"
```

A complete grammar of CQL can be found in

<https://cassandra.apache.org/doc/cql/CQL.html>

It is much simpler than the SQL grammar. But at least my version of CQL shell does not support the full set of queries.

10.6 Further reading on NoSQL*

The course book covers XML, in chapters 11 and 12. The NoSQL approach is more recent, so we must refer to other material. I have found the following useful and readable:

- Martin Fowler, Introduction to NoSQL
https://www.youtube.com/watch?v=qI_g07C_Q5I *A very good overview talk without hype.*
- "Cassandra Essentials Tutorial". <http://www.datastax.com/resources/tutorials>
Recommended by Oscar Söderlund in his Spotify guest talk.
- Kelley Reynolds, "Understanding the Cassandra Data Model from a SQL Perspective", 2010.
<http://rubyscale.com/blog/2010/09/13/understanding-the-cassandra-data-model-from-a-sql-perspective/>
- Chang, Fay; Dean, Jeffrey; Ghemawat, Sanjay; Hsieh, Wilson C; Wallach, Deborah A; Burrows, Michael 'Mike'; Chandra, Tushar; Fikes, Andrew; Gruber, Robert E, "Bigtable: A Distributed Storage System for Structured Data", 2006.
<http://static.googleusercontent.com/media/research.google.com/en//archive/bigtable-osdi06.pdf>

- Giuseppe DeCandia, Deniz Hastorun, Madan Jampani, Gunavardhan Kulkarni, Avinash Lakshman, Alex Pilch, Swaminathan Sivasubramanian, Peter Vosshall and Werner Vogels, "Dynamo: Amazon's Highly Available Key-value Store", 2007.
<http://www.allthingsdistributed.com/files/amazon-dynamo-sosp2007.pdf>
- Jeffrey Dean and Sanjay Ghemawat, MapReduce: "Simplified Data Processing on Large Clusters", 2004.
<http://static.googleusercontent.com/media/research.google.com/en//archive/mapreduce-osdi04.pdf>
- Ralf Lämmel, "Google's MapReduce Programming Model - Revisited", 2008.
<http://userpages.uni-koblenz.de/~laemmel/MapReduce/paper.pdf>