

Programmering av inbyggda system 2014/2015

CPU12 Reference Guide

Stencil: "Assemblerprogrammering.pdf"

Ur innehållet:

- Räknarkretsar ("TIMERS")

- Pulsbreddsmodulering ("PWM")

- Analog-/Digital- omvandling ("AD")

- Seriekommunikation ("SCI")

CRG, Clock Reset Generator

HCS12 har programmerbar arbetstakt. Kontrolleras från CRG-modul.

Address Offset	Use	Access
\$_00	CRG Synthesizer Register (SYNR)	R/W
\$_01	CRG Reference Divider Register (REFDV)	R/W
\$_02	CRG Test Flags Register (CTFLG) ¹	R/W
\$_03	CRG Flags Register (CRGFLG)	R/W
\$_04	CRG Interrupt Enable Register (CRGINT)	R/W
\$_05	CRG Clock Select Register (CLKSEL)	R/W
\$_06	CRG PLL Control Register (PLLCTL)	R/W
\$_07	CRG RTI Control Register (RTICTL)	R/W
\$_08	CRG COP Control Register (COPCTL)	R/W
\$_09	CRG Force and Bypass Test Register (FORBYP) ²	R/W
\$_0A	CRG Test Control Register (CTCTL) ³	R/W
\$_0B	CRG COP Arm/Timer Reset (ARMCOP)	R/W

NOTES:

1. CTFLG is intended for factory test purposes only.
2. FORBYP is intended for factory test purposes only.
3. CTCTL is intended for factory test purposes only.

$$PLLCLK = 2 \times OSCCLK \times \frac{(SYNR + 1)}{(REFDV + 1)}$$

$$BusClock (E) = PLLCLK / 2$$

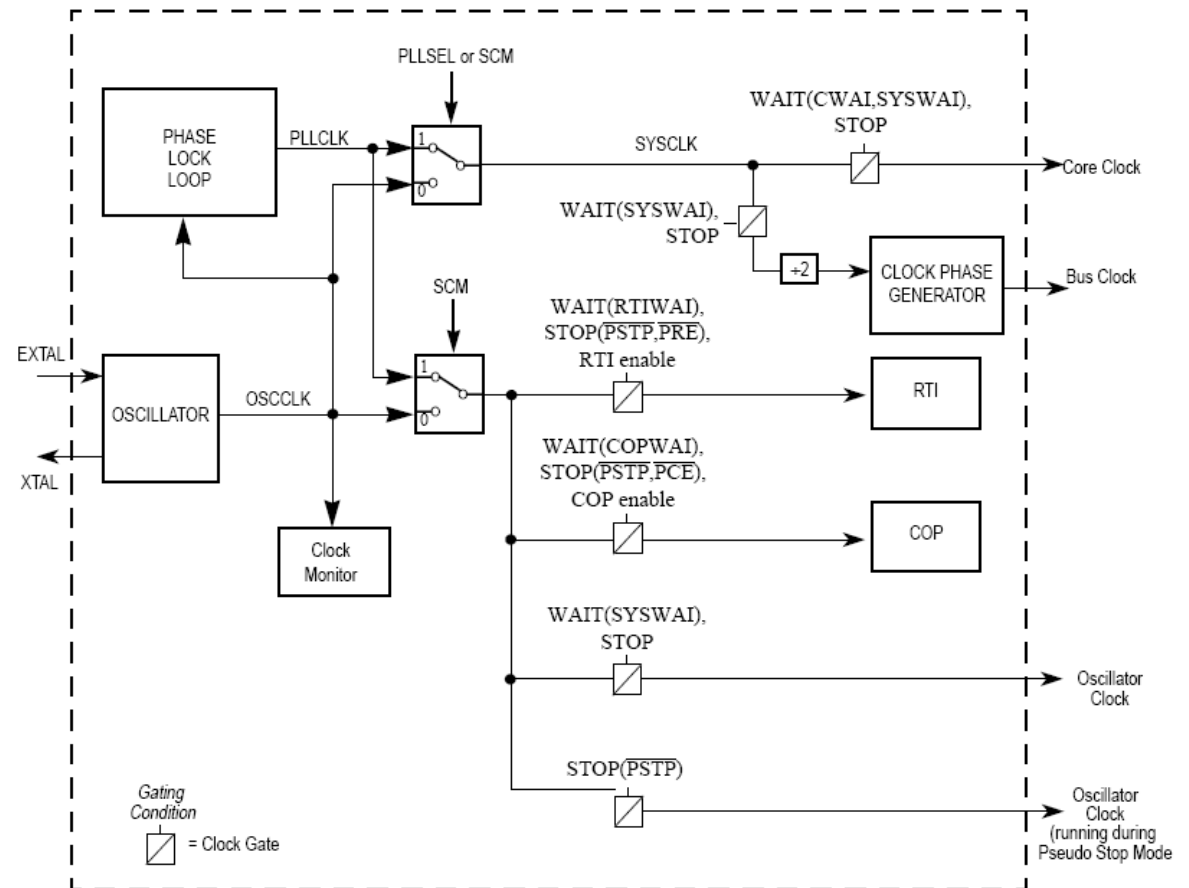

EXEMPEL: Bestäm busfrekvens

Antag 8 MHz kristall.

PLLCLK får aldrig vara *mindre än* OSCCLK eftersom detta äventyrar stabilitetsvillkoren i oscillatorn.

PLLCLK/2 får aldrig vara *större än* nominella arbetsfrekvensen hos kretsen. För första generationens HCS12 innebär detta att $PLLCLK/2 < 25 \text{ MHz}$.

$$50\text{MHz} > 2 \times 8\text{MHz} \times \frac{(SYNR + 1)}{(REFDV + 1)}$$

Sätt:

$$SYNR = 5 \text{ och } REFDV = 1$$

$$2 \times 8\text{MHz} \times \frac{(5 + 1)}{(1 + 1)} = 2 \times 8 \times 3\text{MHz} = 48\text{MHz}$$

Basadress = \$34

Algoritm:

1. Skriv nya värden till SYN_R, REF_{DV}.

2. Vänta tills kretsen "låser" (LOCK=1)

3. Växla till PLL (sätt PLLSEL=1)

Clock Reset Generator (CRG)												
Offset		7	6	5	4	3	2	1	0	Mnemonic	Namn	
\$34	\$0	R	0	0	SYNR5	SYN4	SYN3	SYN2	SYN1	SYN0	SYNR	Synthesizer Register
	0	W										
\$35	\$0	R	0	0	0	0	REFDV3	REFDV2	REFDV1	REFDV0	REFDV	Reference Divide Register
	1	W										
\$36	\$0	R	0	0	0	0	0	0	0	CTFLG	*)Test Flags Register	
	2	W										
\$37	\$0	R	RTIF	PORF	LVRF	LOCKIF	LOCK	SCMIE	SCMIF	SCM	CRGFLG	Flags Register
	3	W										
\$38	\$0	R	RTIE	0	0	LOCKIE	0	0	SCMIE	0	CRGINT	Interrupt Enable Register
	4	W										
\$39	\$0	R	PLLSEL	PSTP	SYSWAI	ROAWAI	PLLWAI	CWAI	RTIWAI	COPWAI	CLKSEL	Clock Select Register
	5	W										
\$3A	\$0	R	CME	PLLON	AUTO	AOQ	0	PRE	PCE	SCME	PLLCTL	PLL Control Register
	6	W										
\$3B	\$0	R	0	RTR6	RTR5	RTR4	RTR3	RTR2	RTR1	RTR0	RTICTL	RTI Control Register
	7	W										
\$3C	\$0	R	WCOP	RSBCK	0	0	0	CR2	CR1	CR0	COPCTL	COP Control Register
	8	W										
\$3D	\$0	R	0	0	0	0	0	0	0	FORBYP	*)Force and Bypass Test Register	
	9	W										
\$3E	\$0	R	0	0	0	0	0	0	0	CTCTL	*)Test Control Register	
	A	W										
\$3F	\$0	R	0	0	0	0	0	0	0	ARMCOP	COP Arm/Timer Reset	
	B	W	Bit7	Bit6	Bit5	Bit4	Bit3	Bit2	Bit1			Bit0

Clock Reset Generator (CRG)												
	Offset	7	6	5	4	3	2	1	0	Mnemonic	Namn	
\$34	\$0	R	0	0	SYN5	SYN4	SYN3	SYN2	SYN1	SYN0	SYNR	Synthesizer Register
	0	W										
\$35	\$0	R	0	0	0	0	REFDV3	REFDV2	REFDV1	REFDV0	REFDV	Reference Divide Register
	1	W										
\$36	\$0	R	0	0	0	0	0	0	0	CTFLG	*)Test Flags Register	
	2	W										
\$37	\$0	R	RTIF	PORF	LVRF	LOCKIF	LOCK	SCMIE	SCMIF	SCM	CRGFLG	Flags Register
	3	W										
\$38	\$0	R	RTIE	0	0	LOCKIE	0	0	SCMIE	0	CRGINT	Interrupt Enable Register
	4	W										
\$39	\$0	R	PLLSEL	PSTP	SYSWAI	ROAWAI	PLLWAI	CWAI	RTIWAI	COPWAI	CLKSEL	Clock Select Register
	5	W										
\$3A	\$0	R	CME	PLLON	AUTO	AOQ	0	PRE	PCE	SCME	PLLCTL	PLL Control Register
	6	W										
\$3B	\$0	R	0	RTR6	RTR5	RTR4	RTR3	RTR2	RTR1	RTR0	RTICTL	RTI Control Register
	7	W										
\$3C	\$0	R	WCOP	RSBCK	0	0	0	CR2	CR1	CR0	COPCTL	COP Control Register
	8	W										
\$3D	\$0	R	0	0	0	0	0	0	0	FORBYP	*)Force and Bypass Test Register	
	9	W										
\$3E	\$0	R	0	0	0	0	0	0	0	CTCTL	*)Test Control Register	
	A	W										
\$3F	\$0	R	0	0	0	0	0	0	0	ARMCOP	COP Arm/Timer Reset	
	B	W	Bit7	Bit6	Bit5	Bit4	Bit3	Bit2	Bit1			Bit0

Beskriv modulens register som en struct

Address Offset	Use	Access
\$_00	CRG Synthesizer Register (SYNR)	R/W
\$_01	CRG Reference Divider Register (REFDV)	R/W
\$_02	CRG Test Flags Register (CTFLG) ¹	R/W
\$_03	CRG Flags Register (CRGFLG)	R/W
\$_04	CRG Interrupt Enable Register (CRGINT)	R/W
\$_05	CRG Clock Select Register (CLKSEL)	R/W
\$_06	CRG PLL Control Register (PLLCTL)	R/W
\$_07	CRG RTI Control Register (RTICTL)	R/W
\$_08	CRG COP Control Register (COPCTL)	R/W
\$_09	CRG Force and Bypass Test Register (FORBYP) ²	R/W
\$_0A	CRG Test Control Register (CTCTL) ³	R/W
\$_0B	CRG COP Arm/Timer Reset (ARMCOP)	R/W

NOTES:

1. CTFLG is intended for factory test purposes only.
2. FORBYP is intended for factory test purposes only.
3. CTCTL is intended for factory test purposes only.

```
/*  
  crgDEFS.h  
*/  
typedef struct sCRG{  
    volatile unsigned char synr;  
    volatile unsigned char refdv;  
    volatile unsigned char ctflg;  
    volatile unsigned char crgflg;  
}CRG;
```

volatile: värdet av symbolen (**synr**) kan ändras utanför programmets kontroll

unsigned: för att inga implicita typkonverteringar ska sättas in av kompilatorn

char: därför att registrens storlek är 8 bitar

..programmering..

Implementera i assembler och 'C'
... Vi löser på tavlan...

Räknarkrets ("timer"), principiell funktion

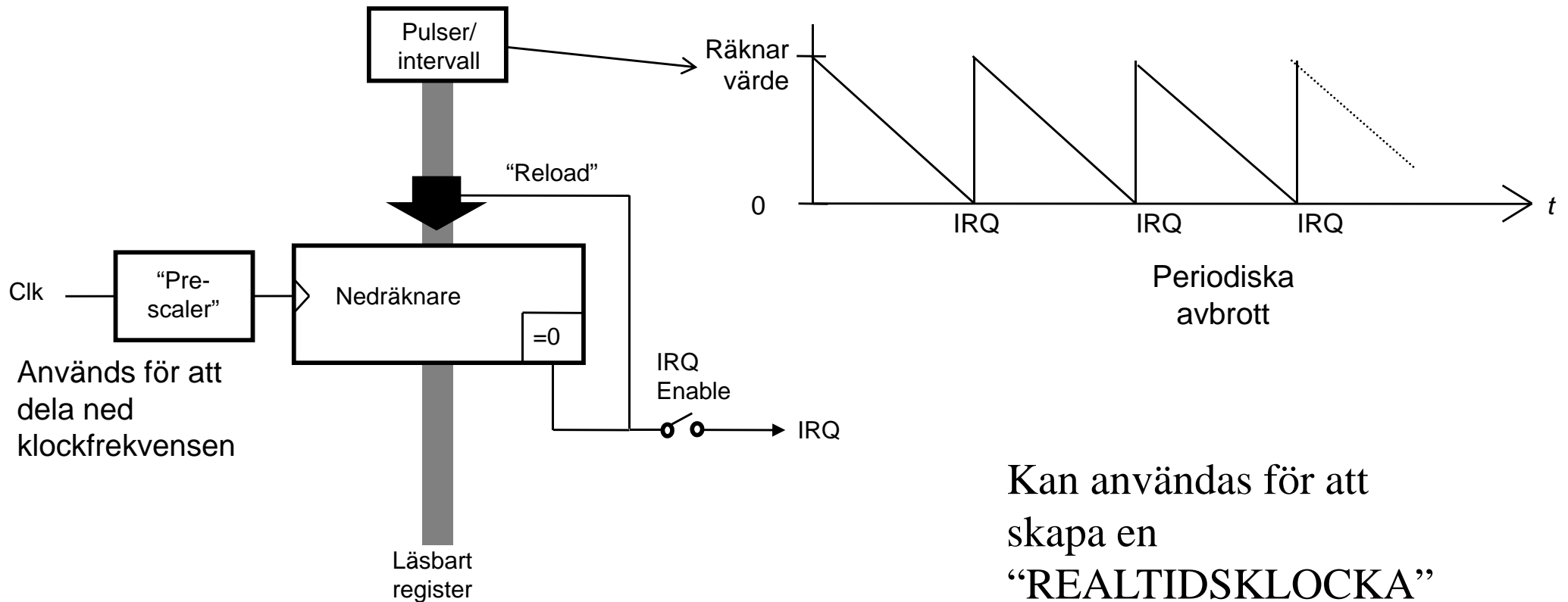

Realtidsklocka i HCS12

Address Offset	Use	Access
\$_00	CRG Synthesizer Register (SYNR)	R/W
\$_01	CRG Reference Divider Register (REFDV)	R/W
\$_02	CRG Test Flags Register (CTFLG) ¹	R/W
\$_03	CRG Flags Register (CRGFLG)	R/W
\$_04	CRG Interrupt Enable Register (CRGINT)	R/W
\$_05	CRG Clock Select Register (CLKSEL)	R/W
\$_06	CRG PLL Control Register (PLLCTL)	R/W
\$_07	CRG RTI Control Register (RTICTL)	R/W
\$_08	CRG COP Control Register (COPCTL)	R/W
\$_09	CRG Force and Bypass Test Register (FORBYP) ²	R/W
\$_0A	CRG Test Control Register (CTCTL) ³	R/W
\$_0B	CRG COP Arm/Timer Reset (ARMCOP)	R/W

Tre olika register används för realtidsklockan

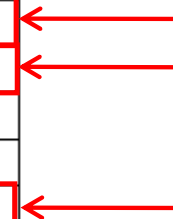
**NOTES:**

1. CTFLG is intended for factory test purposes only.
2. FORBYP is intended for factory test purposes only.
3. CTCTL is intended for factory test purposes only.

Realtidsklocka i HCS12, initiering

Algoritm, initiering

2. Aktivera avbrott från kretsen

1. Skriv tidbas för avbrottsintervall till RTICTL

Clock Reset Generator (CRG)												
Offset		7	6	5	4	3	2	1	0	Mnemonic	Namn	
\$34	\$0	R	0	0	SYN5	SYN4	SYN3	SYN2	SYN1	SYN0	SYNR	Synthesizer Register
	0	W										
\$35	\$0	R	0	0	0	0	REFDV	REFDV	REFDV	REFDV	REFDV	Reference Divide Register
	1	W					3	2	1	0		
\$36	\$0	R	0	0	0	0	0	0	0	0	CTFLG	*)Test Flags Register
	2	W										
\$37	\$0	R				LOCKI			SCM		CRGFLG	Flags Register
	3	W	RTIF	PORF	LVRF	F	LOCK	SCMIE	SCMIF			
\$38	\$0	R			LOCKI				0		CRGINT	Interrupt Enable Register
	4	W	RTIE	0	E			SCMIE				
\$39	\$0	R			SYSWA						CLKSEL	Clock Select Register
	5	W	PLLSEL	PSTP	I	ROAWAI	PLLWAI	CWAI	RTIWAI	COPWAI		
\$3A	\$0	R					0				PLLCTL	PLL Control Register
	6	W	CME	PLLON	AUTO	AOQ		PRE	PCE	SCME		
\$3B	\$0	R	0								RTICTL	RTI Control Register
	7	W		RTR6	RTR5	RTR4	RTR3	RTR2	RTR1	RTR0		
\$3C	\$0	R			0	0	0				COPCTL	COP Control Register
	8	W	WCOP	RSBCK				CR2	CR1	CR0		
\$3D	\$0	R	0	0	0	0	0	0	0	0	FORBYP	*)Force and Bypass Test Register
	9	W										
\$3E	\$0	R	0	0	0	0	0	0	0	0	CTCTL	*)Test Control Register
	A	W										
\$3F	\$0	R	0	0	0	0	0	0	0	0	ARMCOP	COP Arm/Timer Reset
	B	W	Bit7	Bit6	Bit5	Bit4	Bit3	Bit2	Bit1	Bit0		

"Prescaler" för räknarkretsen

$$\frac{OSCCLK}{RTR} = RTIfreq$$

RTR [3:0]	RTR[6:4]							
	000 (OFF)	001	010	011	100	101	110	111
0000	OFF	2 ¹⁰	2 ¹¹	2 ¹²	2 ¹³	2 ¹⁴	2 ¹⁵	2 ¹⁶
0001	OFF	2x2 ¹⁰	2x2 ¹¹	2x2 ¹²	2x2 ¹³	2x2 ¹⁴	2x2 ¹⁵	2x2 ¹⁶
0010	OFF	3x2 ¹⁰	3x2 ¹¹	3x2 ¹²	3x2 ¹³	3x2 ¹⁴	3x2 ¹⁵	3x2 ¹⁶
0011	OFF	4x2 ¹⁰	4x2 ¹¹	4x2 ¹²	4x2 ¹³	4x2 ¹⁴	4x2 ¹⁵	4x2 ¹⁶
0100	OFF	5x2 ¹⁰	5x2 ¹¹	5x2 ¹²	5x2 ¹³	5x2 ¹⁴	5x2 ¹⁵	5x2 ¹⁶
0101	OFF	6x2 ¹⁰	6x2 ¹¹	6x2 ¹²	6x2 ¹³	6x2 ¹⁴	6x2 ¹⁵	6x2 ¹⁶
0110	OFF	7x2 ¹⁰	7x2 ¹¹	7x2 ¹²	7x2 ¹³	7x2 ¹⁴	7x2 ¹⁵	7x2 ¹⁶
0111	OFF	8x2 ¹⁰	8x2 ¹¹	8x2 ¹²	8x2 ¹³	8x2 ¹⁴	8x2 ¹⁵	8x2 ¹⁶
1000	OFF	9x2 ¹⁰	9x2 ¹¹	9x2 ¹²	9x2 ¹³	9x2 ¹⁴	9x2 ¹⁵	9x2 ¹⁶
1001	OFF	10x2 ¹⁰	10x2 ¹¹	10x2 ¹²	10x2 ¹³	10x2 ¹⁴	10x2 ¹⁵	10x2 ¹⁶
1010	OFF	11x2 ¹⁰	11x2 ¹¹	11x2 ¹²	11x2 ¹³	11x2 ¹⁴	11x2 ¹⁵	11x2 ¹⁶
1011	OFF	12x2 ¹⁰	12x2 ¹¹	12x2 ¹²	12x2 ¹³	12x2 ¹⁴	12x2 ¹⁵	12x2 ¹⁶
1100	OFF	13x2 ¹⁰	13x2 ¹¹	13x2 ¹²	13x2 ¹³	13x2 ¹⁴	13x2 ¹⁵	13x2 ¹⁶
1101	OFF	14x2 ¹⁰	14x2 ¹¹	14x2 ¹²	14x2 ¹³	14x2 ¹⁴	14x2 ¹⁵	14x2 ¹⁶
1110	OFF	15x2 ¹⁰	15x2 ¹¹	15x2 ¹²	15x2 ¹³	15x2 ¹⁴	15x2 ¹⁵	15x2 ¹⁶
1111	OFF	16x2 ¹⁰	16x2 ¹¹	16x2 ¹²	16x2 ¹³	16x2 ¹⁴	16x2 ¹⁵	16x2 ¹⁶

Beräkning av tidbas

$$\frac{OSCCLK}{RTR} = RTIfreq \Rightarrow \frac{8 \times 10^6}{RTR} = \frac{1}{10^{-2}} \Rightarrow RTR = x \times 2^y = 8 \times 10^4$$

(Se även exempel i "Stencil 2")

Den bästa approximationen har vi för

$RTR = 100\ 1001 = 513$, som medför: $10 \times 2^{13} = 81920$

Eftersom detta värde är något större än det exakta, kommer vi att få en något längre periodtid, nämligen:

$$\text{avbrottsfrekvens} = 8 \times 10^6 / 81920 = 97.656 \text{ Hz}$$

vilket ger periodtiden:

$$0.01024 \text{ s} = 10,24 \text{ ms.}$$

Klockan kommer alltså att "gå för sakta" som en följd av detta systematiska fel.

Realtidsklocka i HCS12, vid avbrott

Algoritm, kvittera avbrott

1. RTIF = 1

Clock Reset Generator (CRG)													
Offset		7	6	5	4	3	2	1	0	Mnemonic	Namn		
\$34	\$0	R	0	0	SYN5	SYN4	SYN3	SYN2	SYN1	SYN0	SYNR	Synthesizer Register	
	0	W											
\$35	\$0	R	0	0	0	0	REFDV	REFDV	REFDV	REFDV	REFDV	Reference Divide Register	
	1	W					3	2	1	0			
\$36	\$0	R	0	0	0	0	0	0	0	0	CTFLG	*)Test Flags Register	
	2	W											
\$37	\$0	R	RTIF	PORF	LVRF	LOCKIF	LOCK	SCMIE	SCMIF	SCM	CRGFLG	Flags Register	
	3	W											
\$38	\$0	R	RTIE	0	0	LOCKIE	0	0	SCMIE	0	CRGINT	Interrupt Enable Register	
	4	W											
\$39	\$0	R	PLLSEL	PSTP	SYSWAI	ROAWAI	PLLWAI	CWAI	RTIWAI	COPWAI	CLKSEL	Clock Select Register	
	5	W											
\$40	\$0	R			DN	AUTO	AOQ	0	PRE	PCE	SCME	PLLCTL	PLL Control Register
		W											
\$41	\$0	R			6	RTR5	RTR4	RTR3	RTR2	RTR1	RTR0	RTICTL	RTI Control Register
		W											
\$42	\$0	R			CK	0	0	0	CR2	CR1	CR0	COPCTL	COP Control Register
		W											
\$43	\$0	R				0	0	0	0	0	0	FORBYP	*)Force and Bypass Test Register
		W											
\$44	\$0	R				0	0	0	0	0	0	CTCTL	*)Test Control Register
		W											
\$45	\$0	R				0	0	0	0	0	0	ARMCOP	COP Arm/Timer Reset
		W											
		B	W	Bit7	Bit6	Bit5	Bit4	Bit3	Bit2	Bit1	Bit0		

Adress (hex)	Funktion
FFF0	Real Time Interrupt
FFEE	Enhanced Capture Timer channel
FFEC	Enhanced Capture Timer channel 1
FFEA	Enhanced Capture Timer channel 2
....
FF8E	Port P Interrupt
FF8C	PWM Emergency Shutdown
FF8A-FF80	Reserverade

..programmering..

Implementera i assembler och 'C'
... Vi löser på tavlan...

Realtidsklocka med hög upplösning

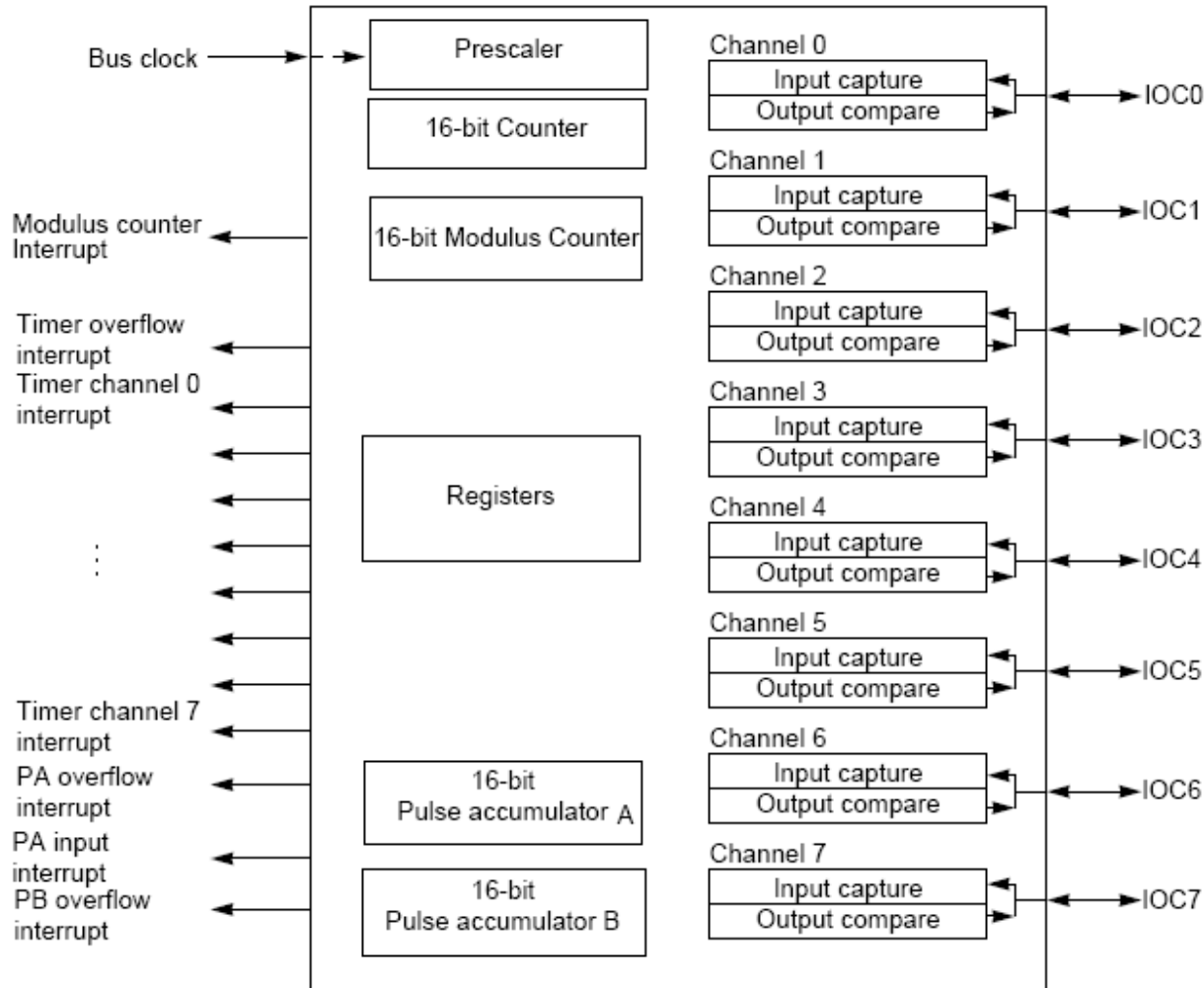

”Enhanced Capture
Timer” (ECT)
En maskincykels
noggrannhet

EXEMPEL:
Arbetstakt= 24 MHz
PERIOD = 24 000
Intervall = 1 ms
Noggrannhet = $1/24\,000\,000$
sek. $\approx 41,7 \times 10^{-9}$ sec.

Programexempel

```

TIOS      EQU      $40
TCNT      EQU      $44
TIE       EQU      $4C
TFLG1    EQU      $4E
TOC_0     EQU      $50

PERIOD    EQU      24000

Init:     MOVB     #1,TIOS ; ch 0 är OC
          MOVB     #1,TIE  ; tillåt IRQ
          LDD      TCNT   ; aktuell cykel
          ADDD     #PERIOD ; addera period
          STD      TOC_0  ; nästa avbrott
          RTS

          ORG      $FFEE
          FDB      TOCirq
  
```

```

TOCirq : MOVB     #1,TFLG1 ; kvittera
          LDD      TCNT   ; ny period
          ADDD     #PERIOD
          STD      TOC_0
          RTI
  
```

Adress (hex)	Funktion
FFF0	Real Time Interrupt
FFEE	Enhanced Capture Timer channel 0
FFEC	Enhanced Capture Timer channel 1
FFEA	Enhanced Capture Timer channel 2
....
FF8E	Port P Interrupt
FF8C	PWM Emergency Shutdown
FF8A-FF80	Reserverade

Pulsbreddsmodulering (PWM)

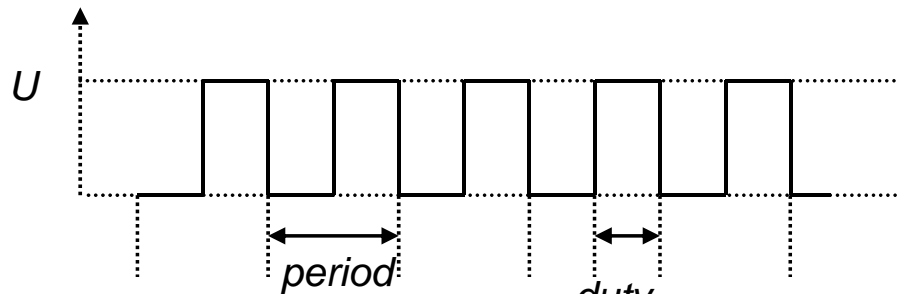

$$U_{out} = \frac{1}{2}U$$

$$U_{out} = \frac{\text{duty-cycle}}{\text{period}}U$$

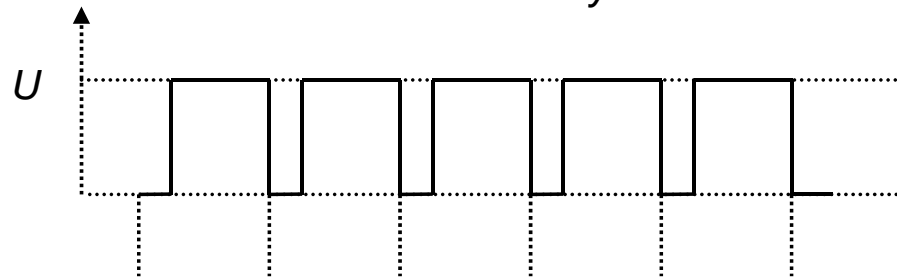

$$U_{out} = \frac{3}{4}U$$

Period och "duty-cycle" är programmerbart

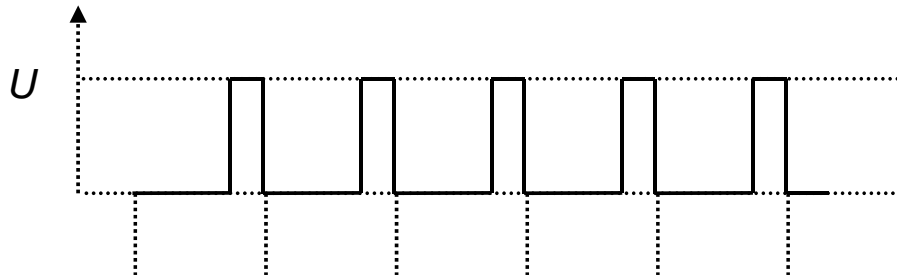

$$U_{out} = \frac{1}{4}U$$

PWM-styrning

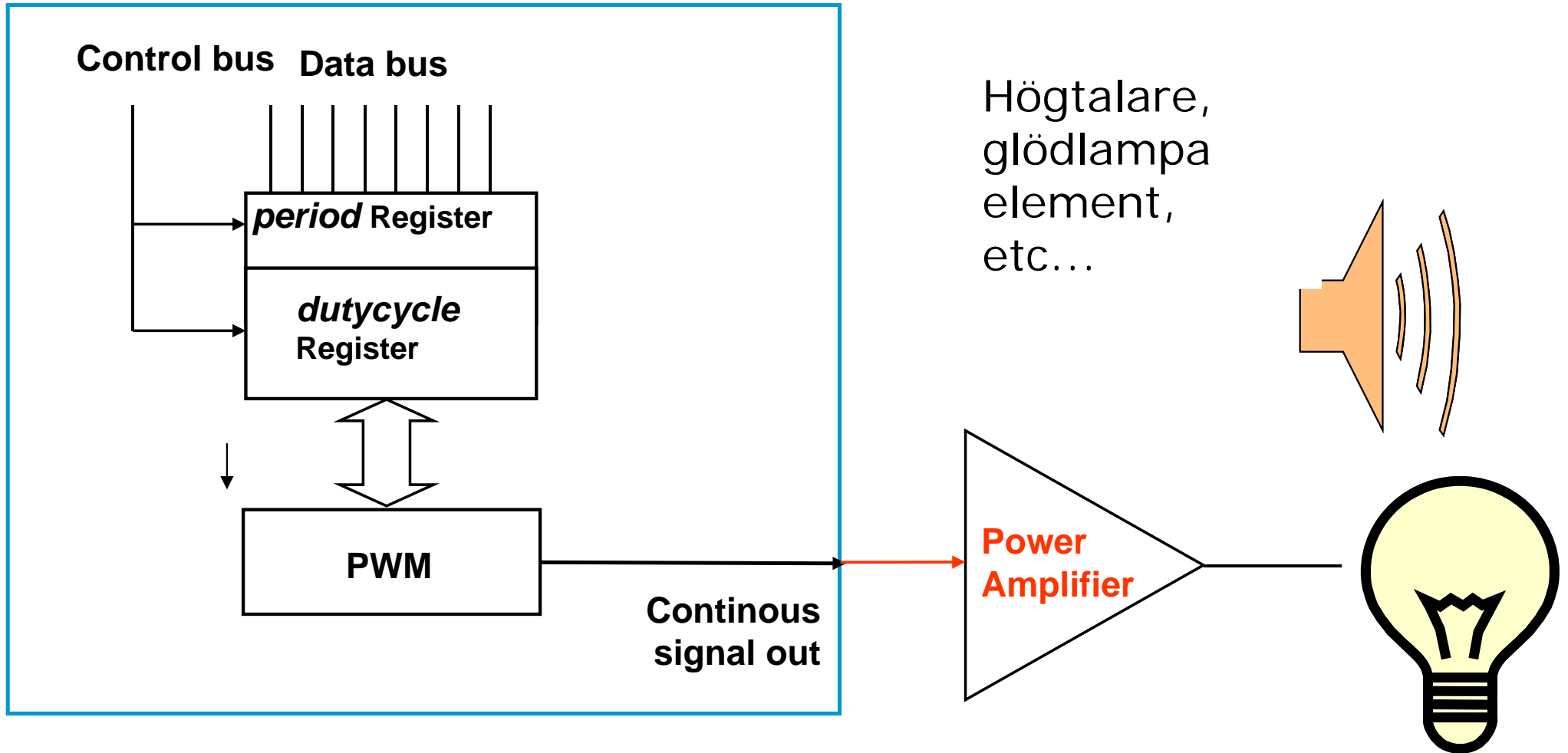

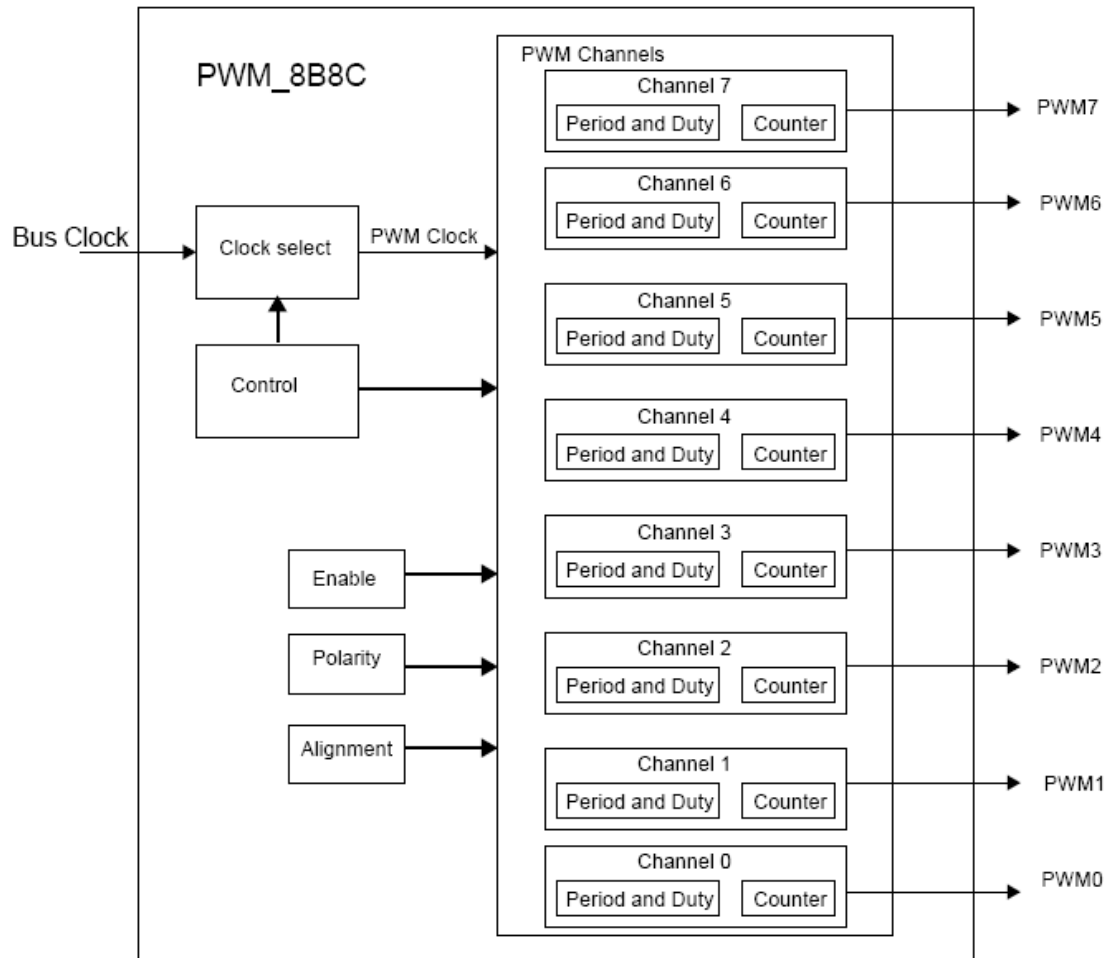

8 * 8 bitars
 eller
 4 * 16 bitars räknare

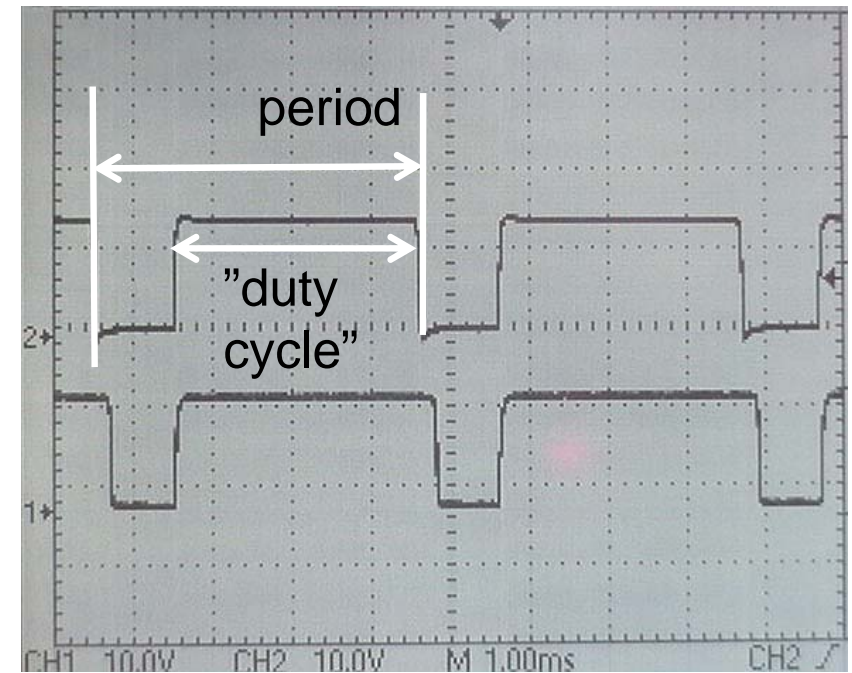



Programexempel

Address	Use	Access
\$_00	PWM Enable Register (PWME)	R/W
\$_01	PWM Polarity Register (PWMPOL)	R/W
\$_02	PWM Clock Select Register (PWMCLK)	R/W
\$_03	PWM Prescale Clock Select Register (PWMPCRCLK)	R/W
\$_04	PWM Center Align Enable Register (PWMCAE)	R/W
\$_05	PWM Control Register (PWMCTL)	R/W
\$_06	PWM Test Register (PWMTST) ¹	R/W
\$_07	PWM Prescale Counter Register (PWMPRSC) ²	R/W
\$_08	PWM Scale A Register (PWMSCLA)	R/W
\$_09	PWM Scale B Register (PWMSCLB)	R/W
\$_0A	PWM Scale A Counter Register (PWMSCNTA) ³	R/W
\$_0B	PWM Scale B Counter Register (PWMSCNTB) ⁴	R/W
\$_0C	PWM Channel 0 Counter Register (PWMCNT0)	R/W
\$_0D	PWM Channel 1 Counter Register (PWMCNT1)	R/W
\$_0E	PWM Channel 2 Counter Register (PWMCNT2)	R/W
\$_0F	PWM Channel 3 Counter Register (PWMCNT3)	R/W
\$_10	PWM Channel 4 Counter Register (PWMCNT4)	R/W
\$_11	PWM Channel 5 Counter Register (PWMCNT5)	R/W
\$_12	PWM Channel 6 Counter Register (PWMCNT6)	R/W
\$_13	PWM Channel 7 Counter Register (PWMCNT7)	R/W
\$_14	PWM Channel 0 Period Register (PWMPER0)	R/W
\$_15	PWM Channel 1 Period Register (PWMPER1)	R/W
\$_16	PWM Channel 2 Period Register (PWMPER2)	R/W
\$_17	PWM Channel 3 Period Register (PWMPER3)	R/W
\$_18	PWM Channel 4 Period Register (PWMPER4)	R/W
\$_19	PWM Channel 5 Period Register (PWMPER5)	R/W
\$_1A	PWM Channel 6 Period Register (PWMPER6)	R/W
\$_1B	PWM Channel 7 Period Register (PWMPER7)	R/W
\$_1C	PWM Channel 0 Duty Register (PWMDTY0)	R/W
\$_1D	PWM Channel 1 Duty Register (PWMDTY1)	R/W
\$_1E	PWM Channel 2 Duty Register (PWMDTY2)	R/W
\$_1F	PWM Channel 3 Duty Register (PWMDTY3)	R/W
\$_20	PWM Channel 4 Duty Register (PWMDTY4)	R/W
\$_21	PWM Channel 5 Duty Register (PWMDTY5)	R/W
\$_22	PWM Channel 6 Duty Register (PWMDTY6)	R/W
\$_23	PWM Channel 7 Duty Register (PWMDTY7)	R/W
\$_24	PWM Shutdown Register (PWMSDN)	R/W
\$_25	Reserved	R
\$_26	Reserved	R
\$_27	Reserved	R

```

; PWM initiering
PWME           EQU     $A0
PWPOL          EQU     $A1
PWMPCRCLK      EQU     $A3
PWMPER0        EQU     $B4
PWMDTY0        EQU     $BC

; låg nivå startar period
                CLR     PWMPOL

; c:a 4 ms periodtid
                MOVB    #$77, PWMPCRCLK

; pwm kanal 0
                MOVB    #$FF, PWMPER0

; börja med 80% duty cycle..
                MOVB    #$D0, PWMDTY0

; aktivera kanal 0
                MOVB    #1, PWME
    
```

Analog-/Digital- omvandling

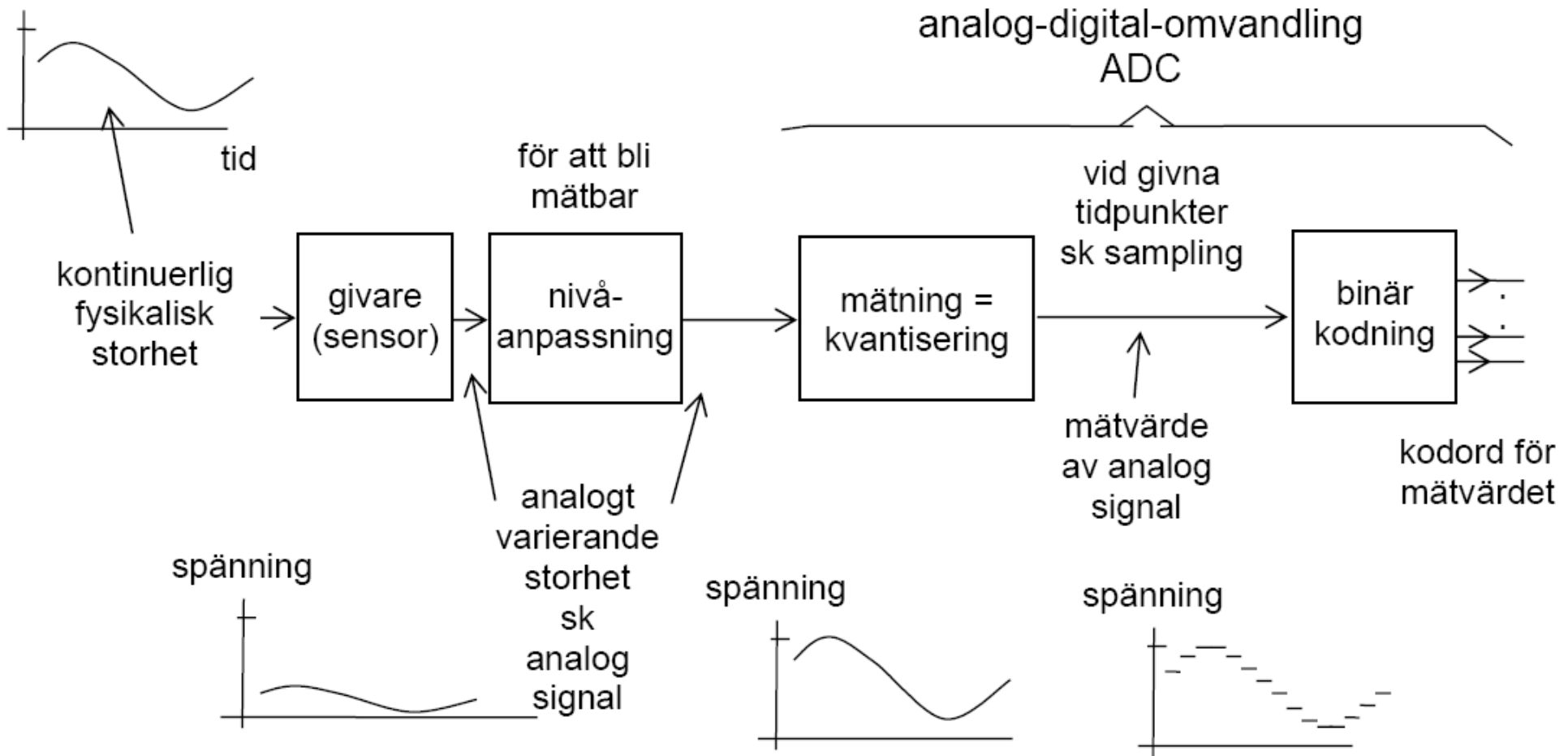

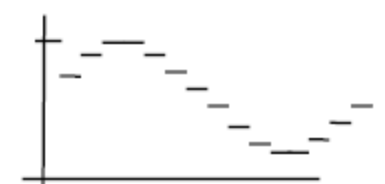
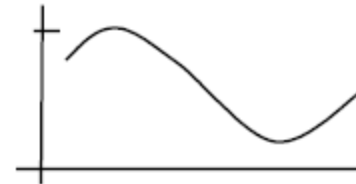
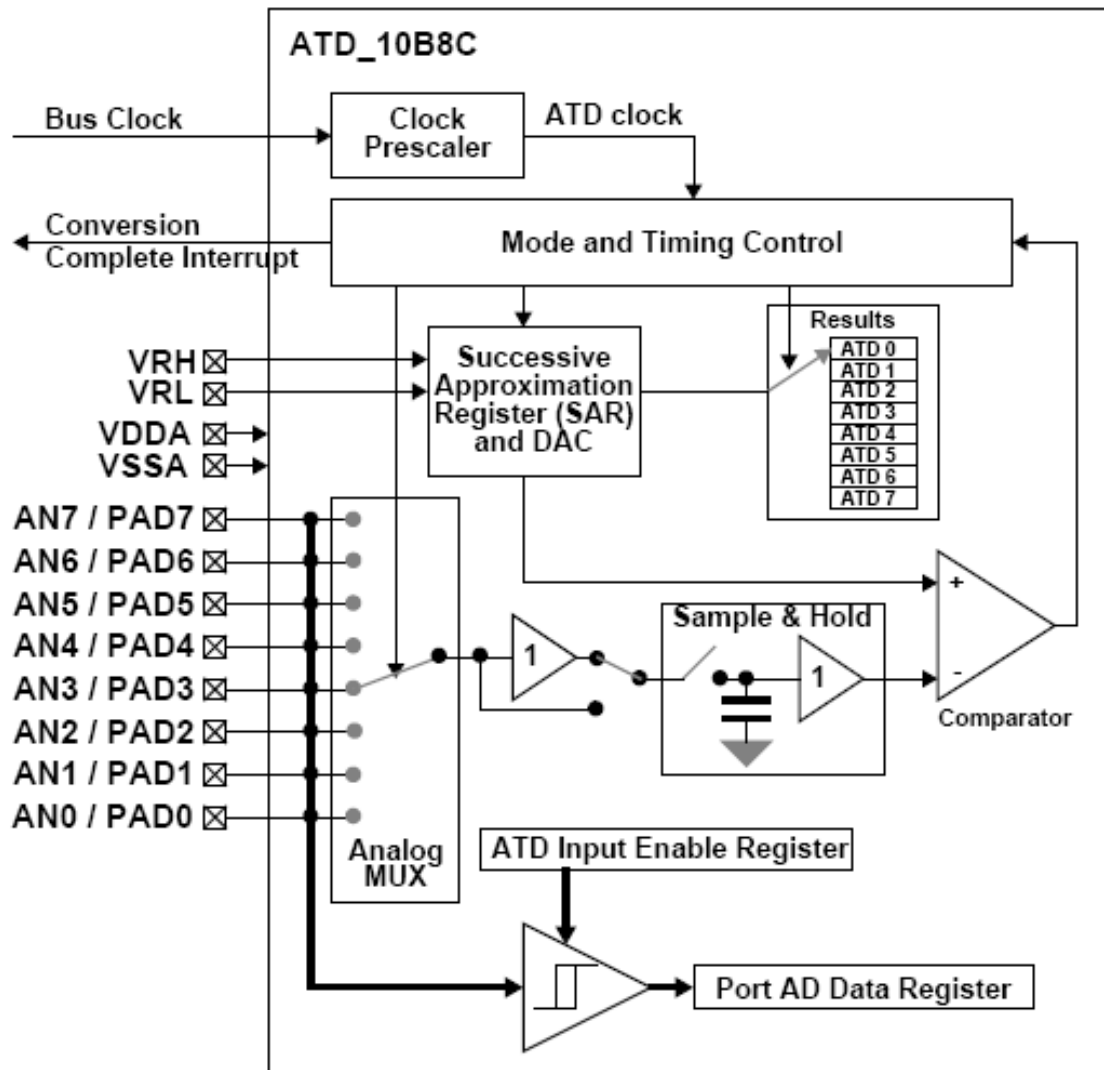

Multiplex
8 kanaler.

Programexempel

Address Offset	Use	Access
\$_00	ATD Control Register 0 (ATDCTL0) ¹	R
\$_01	ATD Control Register 1 (ATDCTL1) ²	R
\$_02	ATD Control Register 2 (ATDCTL2)	R/W
\$_03	ATD Control Register 3 (ATDCTL3)	R/W
\$_04	ATD Control Register 4 (ATDCTL4)	R/W
\$_05	ATD Control Register 5 (ATDCTL5)	R/W
\$_06	ATD Status Register 0 (ATDSTAT0)	R/W
\$_07	Unimplemented	
\$_08	ATD Test Register 0 (ATDTEST0) ³	R
\$_09	ATD Test Register 1 (ATDTEST1)	R/W
\$_0A	Unimplemented	
\$_0B	ATD Status Register 1 (ATDSTAT1)	R
\$_0C	Unimplemented	
\$_0D	ATD Input Enable Register (ATDDIEN)	R/W
\$_0E	Unimplemented	
\$_0F	Port Data Register (PORTAD)	R
\$_10, \$_11	ATD Result Register 0 (ATDDR0H, ATDDR0L)	R/W
\$_12, \$_13	ATD Result Register 1 (ATDDR1H, ATDDR1L)	R/W
\$_14, \$_15	ATD Result Register 2 (ATDDR2H, ATDDR2L)	R/W
\$_16, \$_17	ATD Result Register 3 (ATDDR3H, ATDDR3L)	R/W
\$_18, \$_19	ATD Result Register 4 (ATDDR4H, ATDDR4L)	R/W
\$_1A, \$_1B	ATD Result Register 5 (ATDDR5H, ATDDR5L)	R/W
\$_1C, \$_1D	ATD Result Register 6 (ATDDR6H, ATDDR6L)	R/W
\$_1E, \$_1F	ATD Result Register 7 (ATDDR7H, ATDDR7L)	R/W

```

; AD initiering
; Högerjustera resultat, unipolärt
; kontinuerlig mode (scan), AD kanal 6

```

```

MOVW    #$A6,ATDCTL5

```

```

; upplösning

```

```

MOVW    #$E5,ATDCTL4

```

```

; en konverteringssekvens

```

```

MOVW    #$40,ATDCTL3

```

```

; normal mode

```

```

MOVW    #$C0,ATDCTL2

```

```

; Vänta tills omvandling klar

```

```

wAD:

```

```

BRCLR   ATD0STAT0,$$80,wAD

```

```

; När resultat färdigt, läs

```

```

LDAB    ATD0DR0L

```

```

...

```

Seriekommunikation, SCI

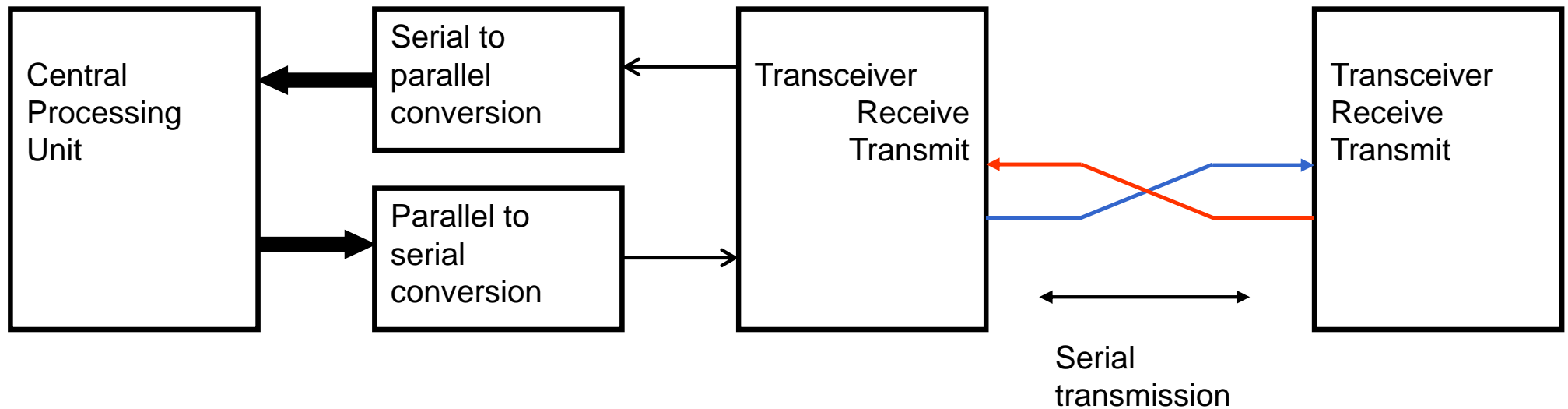
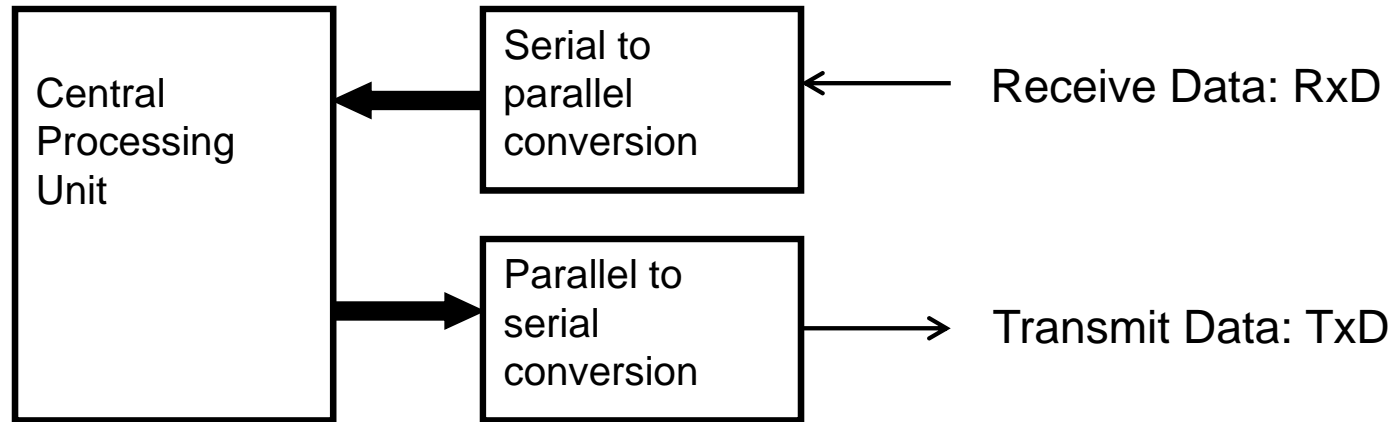

Sändare

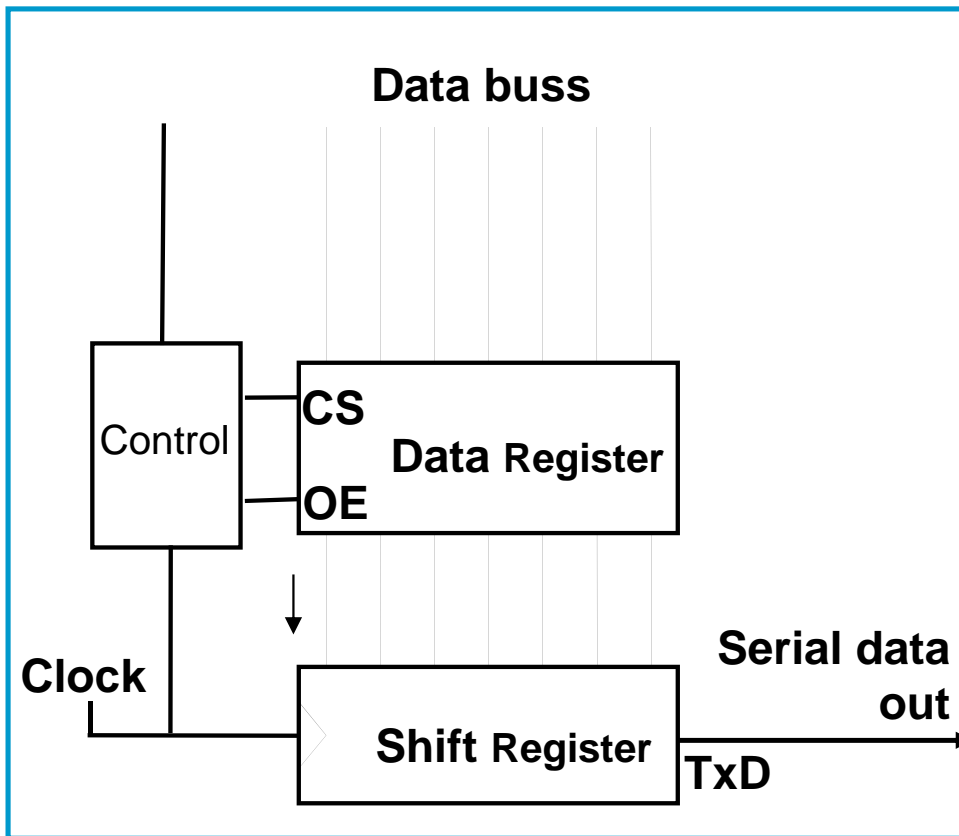

Mottagare

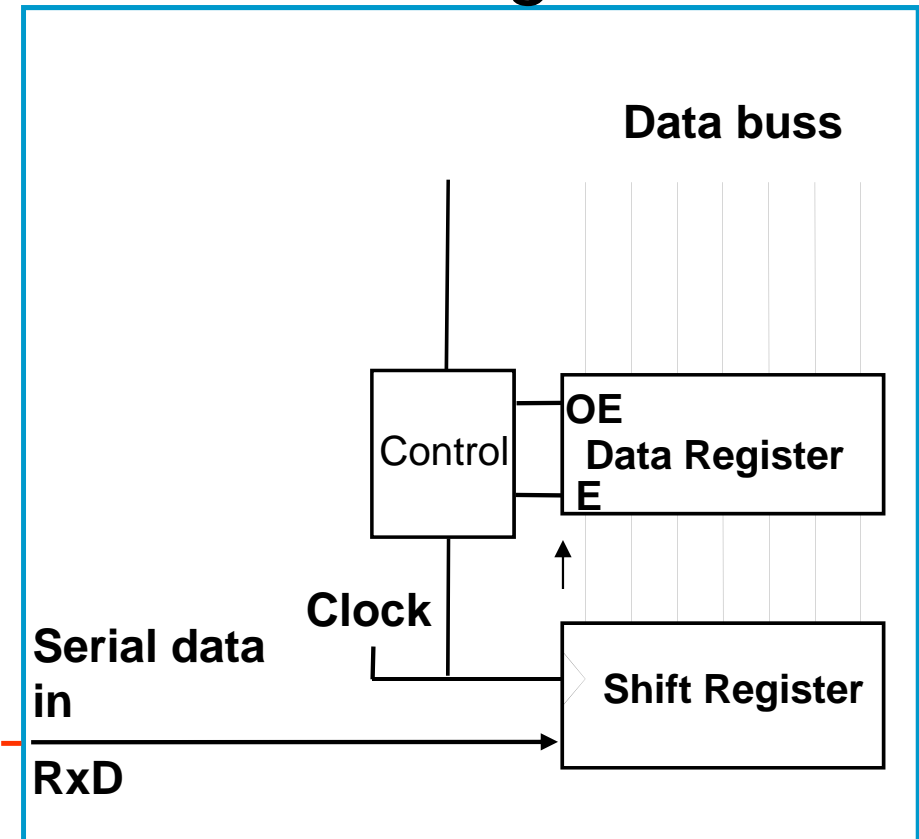

Sändare och mottagares klockor går i samma takt

RS232 – överföring av tecknet 'z'

tecknet "z" representeras av bitmönstret "0111 1010" (ASCII-tecken).

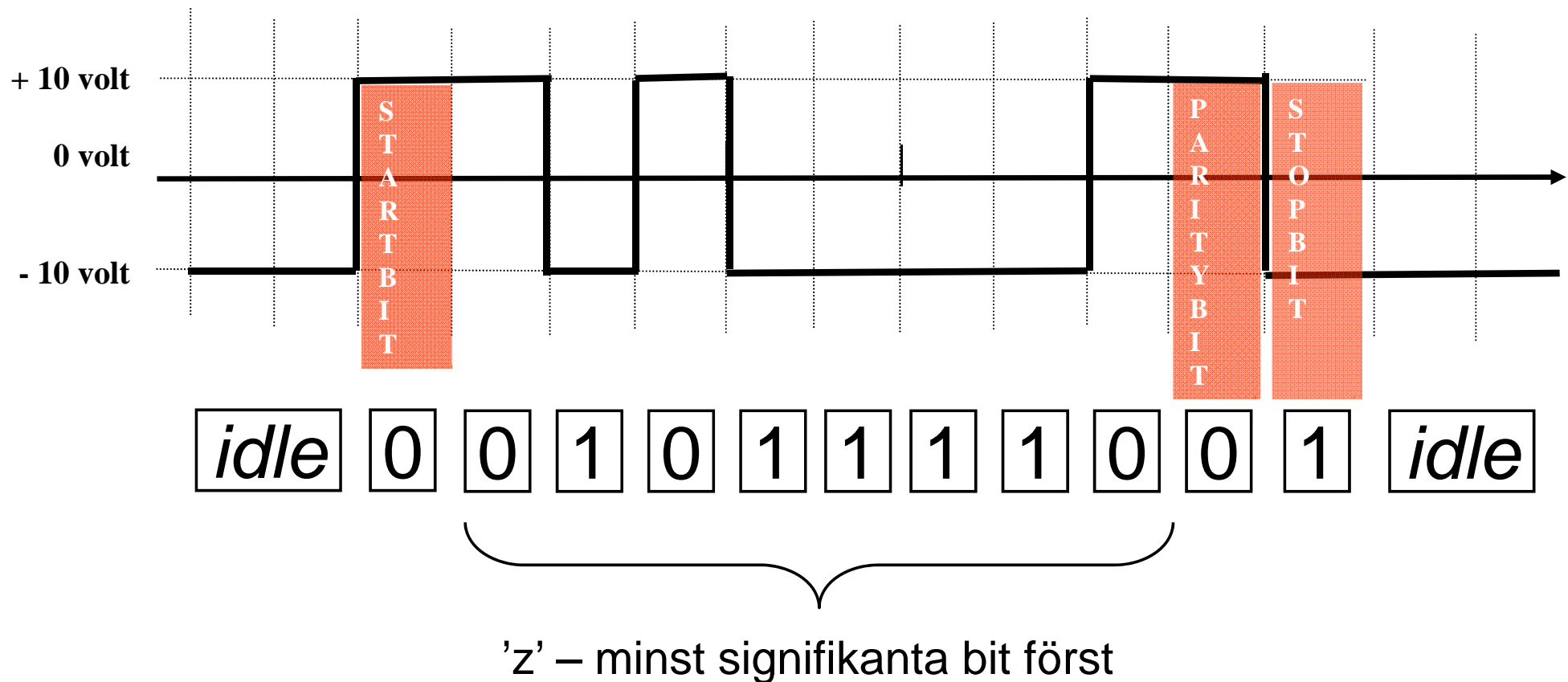

Initiering, "busy-wait"

Basadress = \$C8

Algoritm:
 1. Initiera
 BAUDRATE

2. Aktivera
 Transmitter
 Receiver

Serial Communication Interface (SCI)											
Offset		7	6	5	4	3	2	1	0	Mnemonic	Namn
\$00	R	0	0	0	SBR12	SBR11	SBR10	SBR9	SBR8	SCIBDH	Baud Rate Register High
	W										
\$01	R	SBR7	SBR6	SBR5	SBR4	SBR3	SBR2	SBR1	SBR0	SCIBDL	Baud Rate Register Low
	W										
\$02	R	LOOPS	SCISWAI	RSRC	M	WAKE	ILT	PE	PT	SCICR1	Control Register 1
	W										
\$03	R	TIE	TCIE	RIE	ILIE	TE	RE	RWU	SBK	SCICR2	Control Register 2
	W										
\$04	R	TDRE	TC	RDRF	IDLE	OR	NF	FE	PF	SCISR1	Status Register 1
	W										
\$05	R	0	0	0	0	0	BRK13	TXDIR	RAF	SCISR2	Status Register 2
	W										
\$06	R	R8	T8	0	0	0	0	0	0	SCIDRH	Data Register High
	W										
\$07	R	R7	R6	R5	R4	R3	R2	R1	R0	SCIDRL	Data Register Low
	W	T7	T6	T5	T4	T3	T2	T1	T0		

```

SCI0BD:      EQU      $C8      ; SCI 0 baudrate-register (16 bit).
SCI0CR2:    EQU      $CB      ; SCI 0 styr-register 2.
; Bitdefinitioner, styrregister
TE:         EQU      $08      ; Transmitter enable.
RE:         EQU      $04      ; Receiver enable.
    
```

Skriv tecken via SCI

Serial Communication Interface (SCI)											
Offset		7	6	5	4	3	2	1	0	Mnemonic	Namn
\$00	R	0	0	0	SBR12	SBR11	SBR10	SBR9	SBR8	SCIBDH	Baud Rate Register High
	W										
\$01	R	SBR7	SBR6	SBR5	SBR4	SBR3	SBR2	SBR1	SBR0	SCIBDL	Baud Rate Register Low
	W										
\$02	R	LOOPS	SCISWAI	RSRC	M	WAKE	ILT	PE	PT	SCICR1	Control Register 1
	W										
\$03	R	TIE	TCIE	RIE	ILIE	TE	RE	RWU	SBK	SCICR2	Control Register 2
	W										
\$04	R	TDRE	TC	RDRF	IDLE	OR	NF	FE	PF	SCISR1	Status Register 1
	W										
\$05	R	0	0	0	0	0	BRK13	TXDIR	RAF	SCISR2	Status Register 2
	W										
\$06	R	R8	T8	0	0	0	0	0	0	SCIDRH	Data Register High
	W										
\$07	R	R7	R6	R5	R4	R3	R2	R1	R0	SCIDRL	Data Register Low
	W	T7	T6	T5	T4	T3	T2	T1	T0		

Algoritm:

TDRE =

(Transmit Data Register Empty)

1. Om TDRE=1
SCIDRL=tecken

```

SCI0SR1:    EQU    $CC    ; SCI 0 status-register 1.
SCI0DRL:    EQU    $CF    ; SCI 0 data-register låg byte.
; Bitdefinitioner, statusregister
TDRE:      EQU    $80    ; Transmit data register empty status bit.
    
```

Läs tecken från SCI

Serial Communication Interface (SCI)											
Offset		7	6	5	4	3	2	1	0	Mnemonic	Namn
\$00	R	0	0	0	SBR12	SBR11	SBR10	SBR9	SBR8	SCIBDH	Baud Rate Register High
	W										
\$01	R	SBR7	SBR6	SBR5	SBR4	SBR3	SBR2	SBR1	SBR0	SCIBDL	Baud Rate Register Low
	W										
\$02	R	LOOPS	SCISWAI	RSRC	M	WAKE	ILT	PE	PT	SCICR1	Control Register 1
	W										
\$03	R	TIE	TCIE	RIE	ILIE	TE	RE	RWU	SBK	SCICR2	Control Register 2
	W										
\$04	R	TDRE	TC	RDRF	IDLE	OR	NF	FE	PF	SCISR1	Status Register 1
	W										
\$05	R	0	0	0	0	0	BRK13	TXDIR	RAF	SCISR2	Status Register 2
	W										
\$06	R	R8	T8	0	0	0	0	0	0	SCIDRH	Data Register High
	W										
\$07	R	R7	R6	R5	R4	R3	R2	R1	R0	SCIDRL	Data Register Low
	W	T7	T6	T5	T4	T3	T2	T1	T0		

Algoritm:

RDRF =

(Receive Data Register Full)

1. Om RDRF =1
tecken=SCIDRL

```

SCI0SR1:    EQU    $CC    ; SCI 0 status-register 1.
SCI0DRL:    EQU    $CF    ; SCI 0 data-register låg byte.
; Bitdefinitioner, statusregister
RDRF:       EQU    $20    ; Receive data register full status bit.
    
```

Bestämna Baudrate-värde

exempel: 9600 baud

PLLCLK=48 MHz -> E-klocka = 24 MHz

$$BR = \frac{PLLCLK / 2}{16 \times baudrate}$$

$$baudrate = \frac{PLLCLK / 2}{16 \times BR}$$

9 600	$\frac{24 \times 10^6}{16 \times 9600} = 156,25$	$\frac{24 \times 10^6}{16 \times 156} \approx 9615$, $\frac{24 \times 10^6}{16 \times 157} \approx 9585$
-------	--	---	---

```

Eclock:          EQU    24000000      ; 24 MHz
; BaudRate register värden, baseras på PLL-klocka
Baud9600:       EQU    (Eclock/(16*9600))
    
```

..programmering..

Implementera i assembler och 'C'
... Vi löser på tavlan...