

MC68HCS12 - översikt

MC68HC12,
Arbetsbok för MC12
CPU12 Reference Guide

Ur innehållet:
Programmerarens bild
Översikt, "single-chip-computer" DG256

Instruktionsuppsättning

"ISA" – Instruction Set Architecture

- ⊕ Vilka operationer kan utföras ?
 - Instruktionsgrupper
- ⊕ Hur lagras operanderna förutom i minnet ?
 - Korttidslagring
- ⊕ Hur nås operander i minnet?
 - Adresseringssätt
- ⊕ Vilka typer/storlekar av operander kan hanteras ?
 - Generella/speciella register, registerstorlek

Programmerarens bild – datatyper/storlek

	char (8)	short int (16)	long int (32)	long int (64)	floating point (IEEE)	pointers
68HCS12	X	X				16/20 bit
Coldfire V1	X	X	X			32 bit
Coldfire V4	X	X	X		X	32 bit
PowerPC	X	X	X		X	32 bit
PowerPC (64)	X	X		X	X	64 bit
8086	X	X				16/20 bit
80386	X	X	X			32 bit
80486	X	X	X		X	32 bit
X86-32	X	X	X		X	32 bit
X86-64	X	X		X	X	64 bit

Programmerarens bild – adresserbart minne

ADRESSBUSS	RANDOM ACCESS
16 bitar	$2^{16} = 65\,536$ byte = 64 kbyte
20 bitar	$2^{20} = 1\,048\,576$ byte = 1 024 kbyte = 1 Mbyte
24 bitar	$2^{24} = 16\,777\,216$ byte = 16 384 kbyte = 16 MByte
32 bitar	$2^{32} = 4\,294\,967\,296$ byte = 4 194 304 kbyte = 4 096 Mbyte = 4 Gbyte
64 bitar	$2^{64} = 1,844674407 \cdot 10^{19}$ byte = 16 Ebyte

Freescal 68HCS12

- HCS12 adressrum, IO och minne
- CPU12, klockor och räknare
- "Random Access"- Minne
 - RWM, FLASH, EEPROM
- Periferienheter
 - Parallell Input/Output:
 - Seriell kommunikation
 - AD
 - PWM

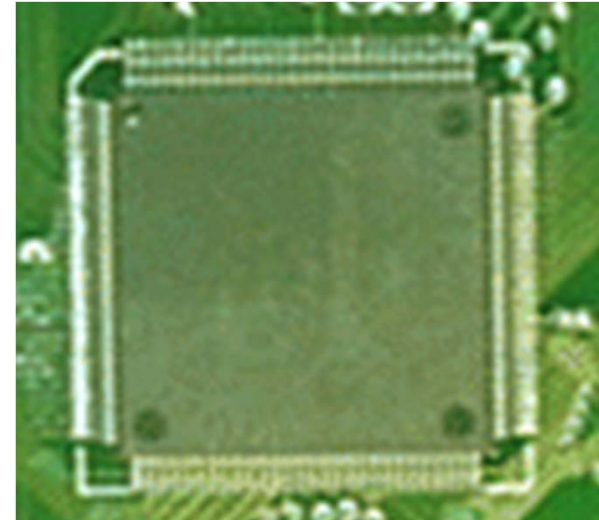

Historik

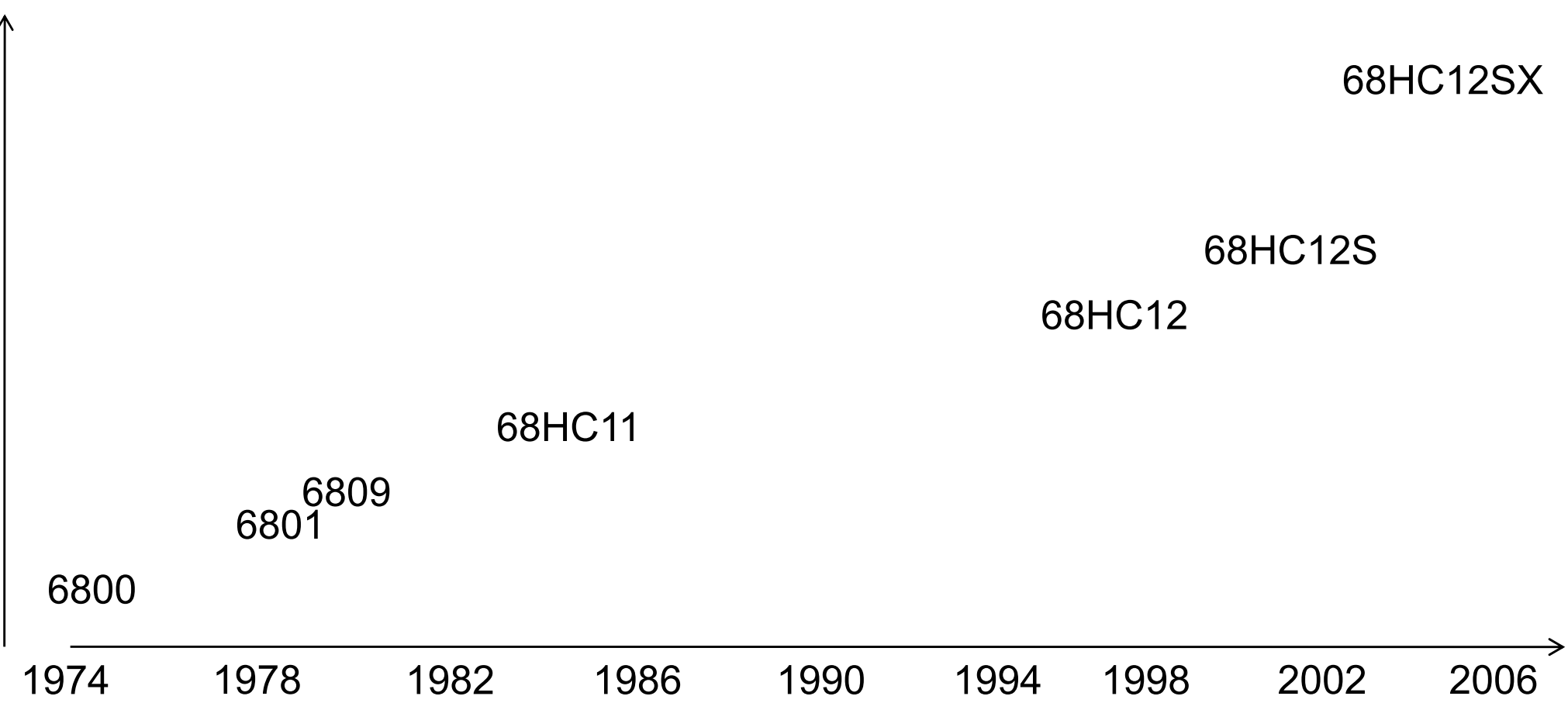

HCS12DG256, blockdiagram

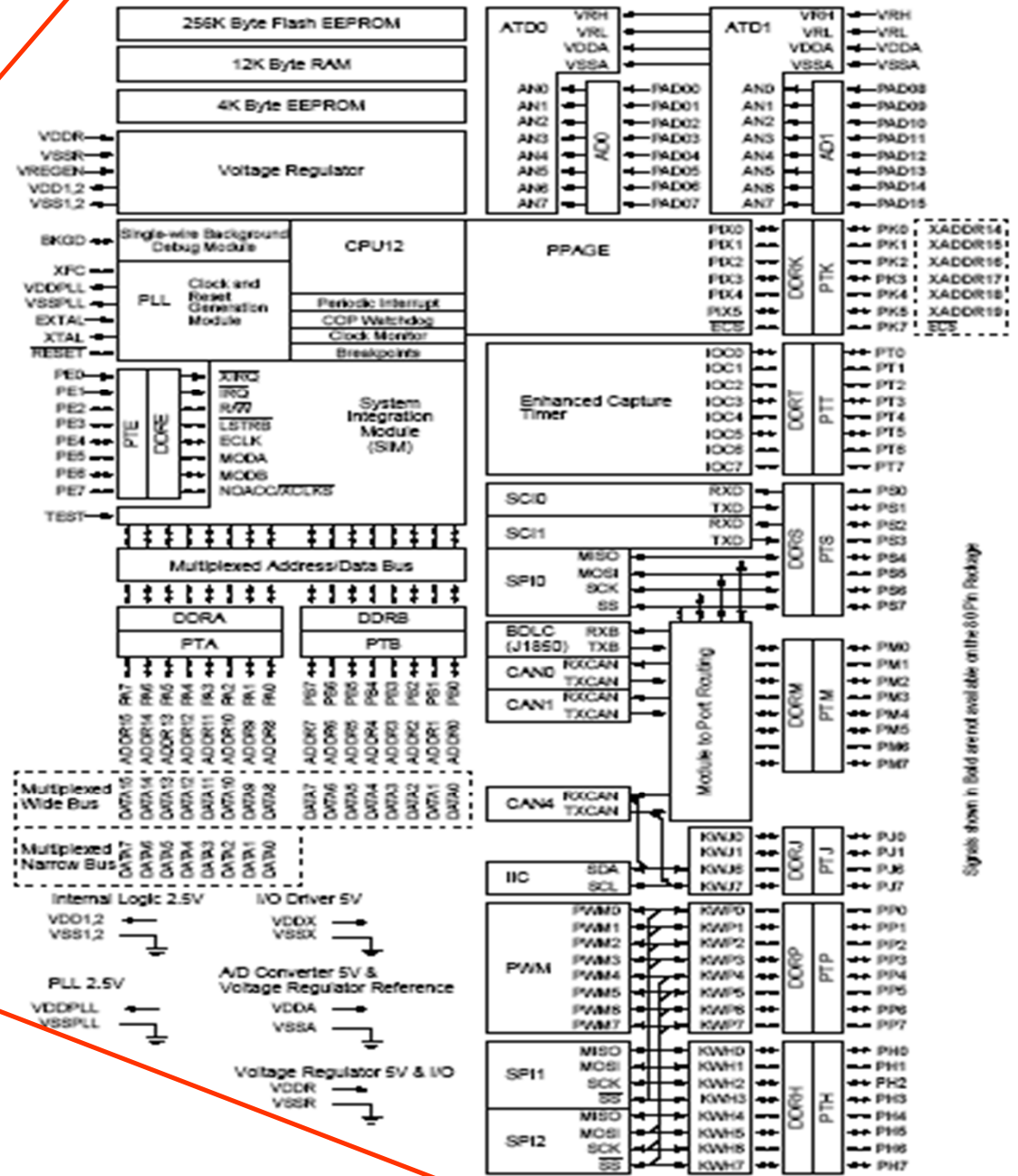
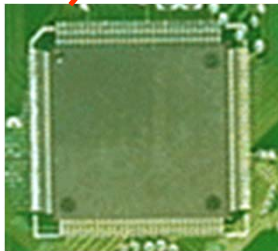

Signals shown in bold are not available on the 60Pin Package

HCS12DG256, "core"

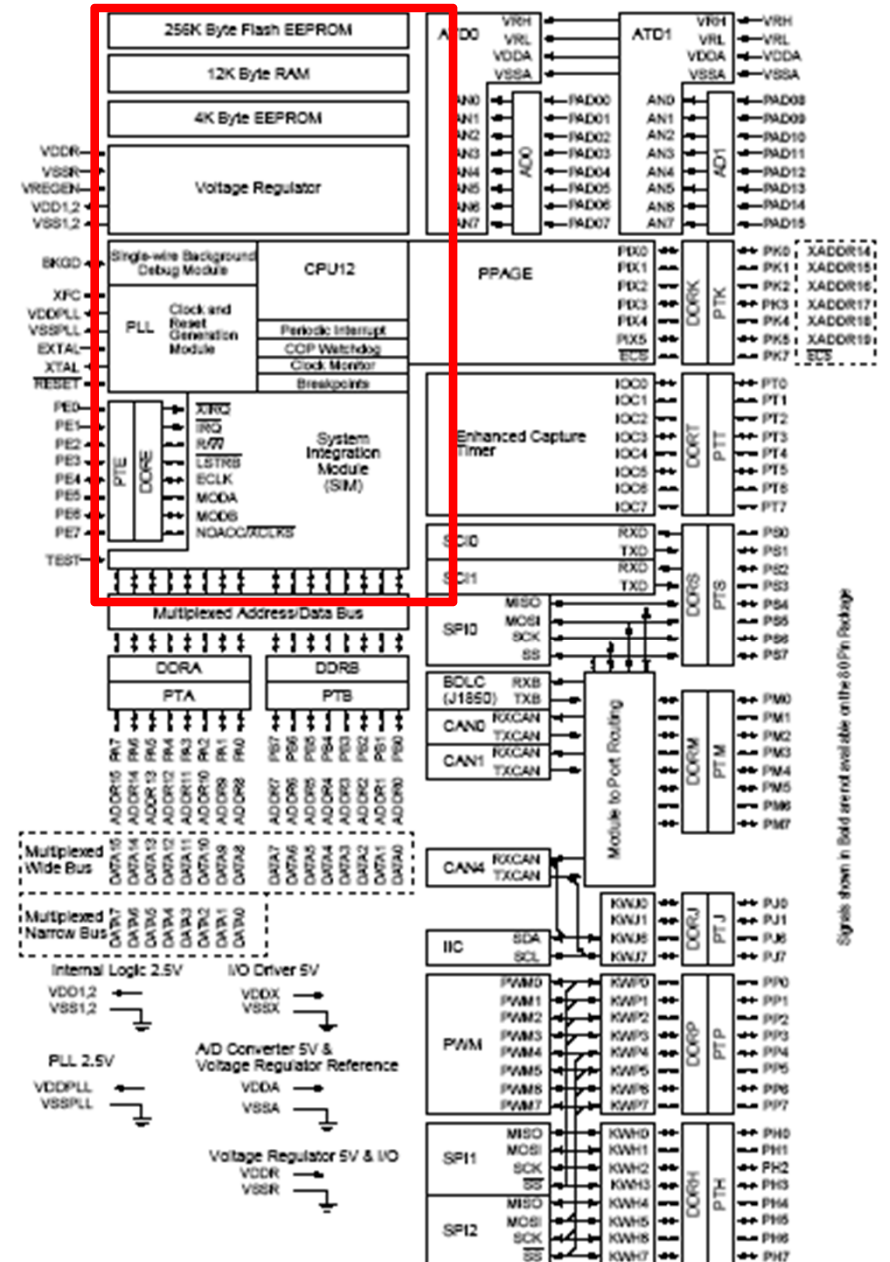
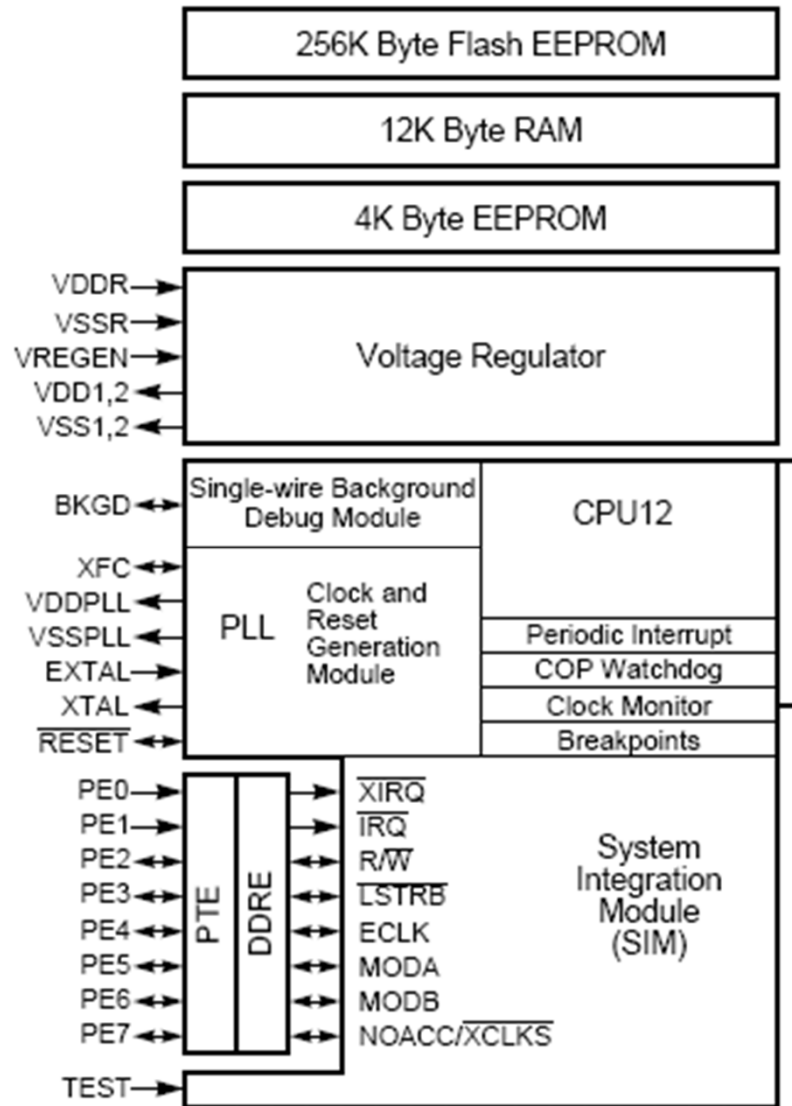

Signals shown in bold are not available on the 60 Pin Package

HCS12DG256, "core"

Spänningsregulatorer (flera olika spänningar används internt)

"Background Debug Mode" för test/avlusning

En kristall utgör bas för alla klockfrekvenser i systemet

Realtidsklocka och andra klockfunktioner

Programmerbara funktioner

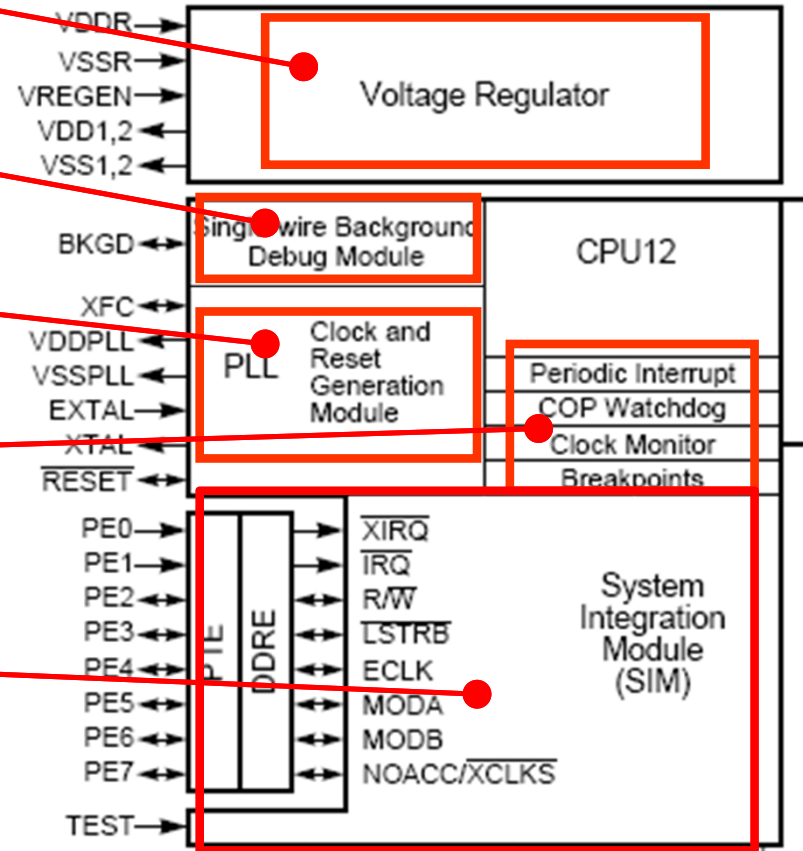



Primärminne

Icke flyktigt minne

Upp till 256 Kbyte i "minnesbankar"

48 kB utan användning av "bankar"

4 kB EEPROM

Flyktigt minne

12 kB RAM (=RWM)

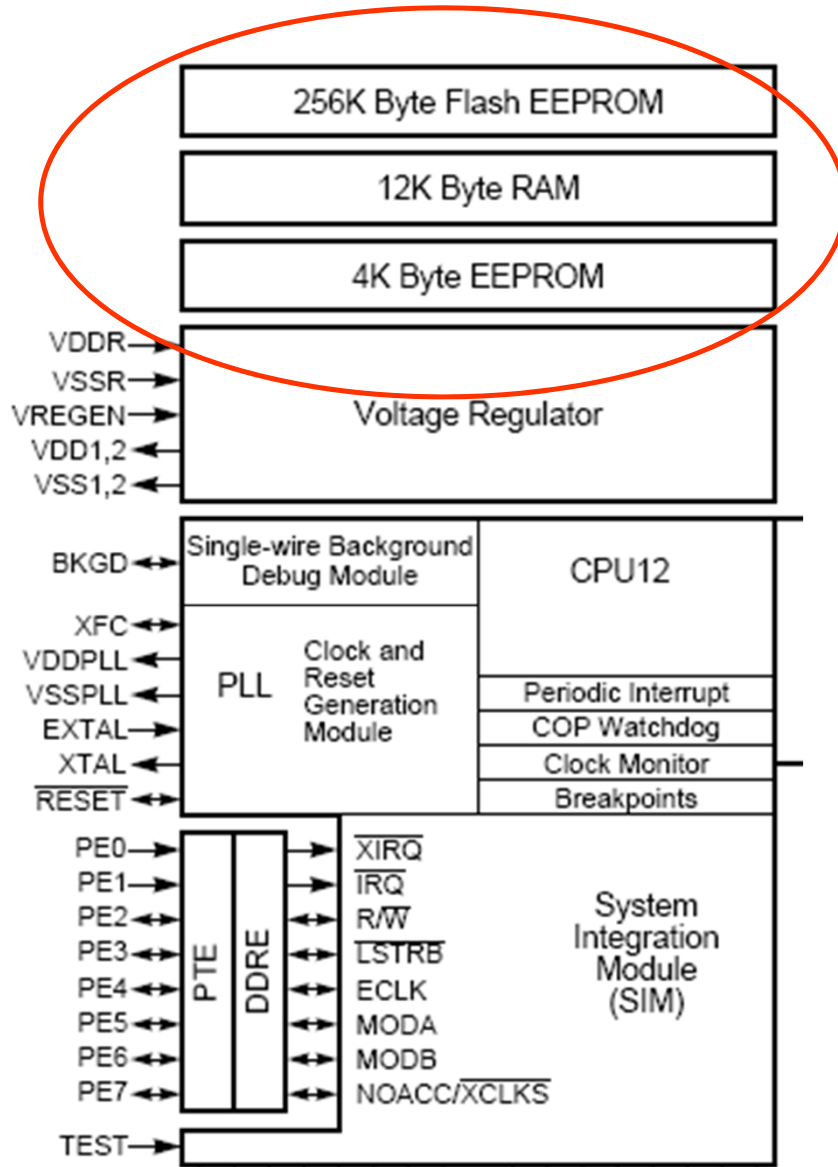

EXEMPEL, linjärt adressrum

256K Byte Flash EEPROM
12K Byte RAM
4K Byte EEPROM

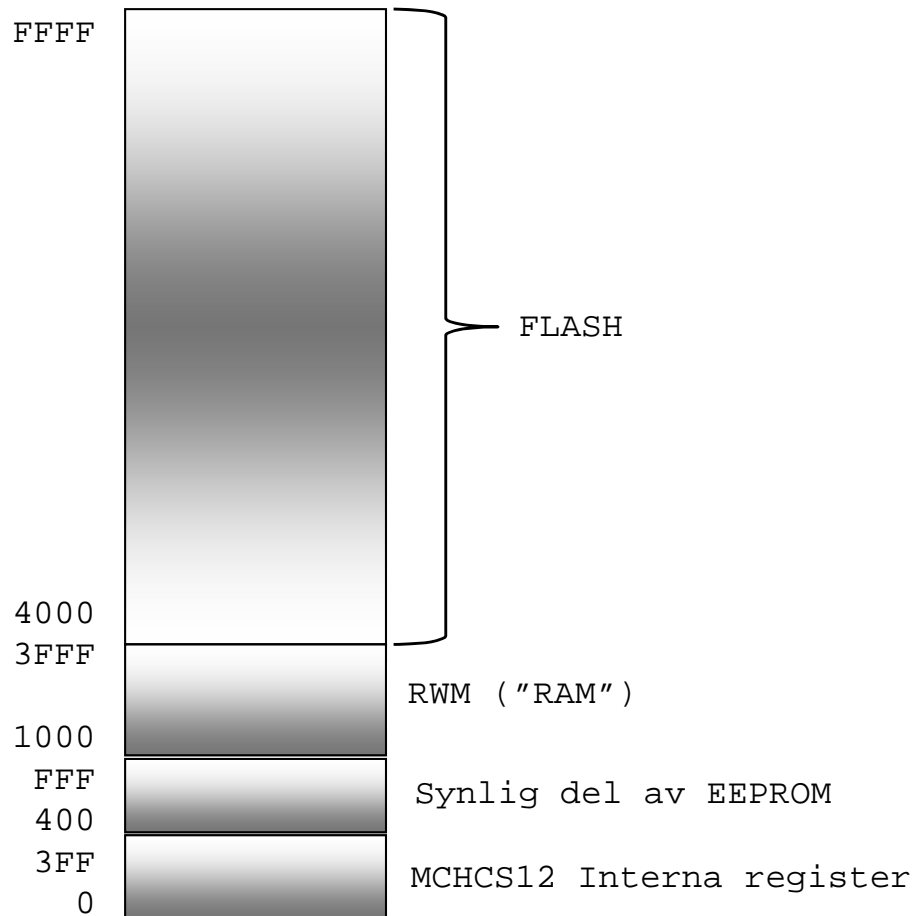

EXEMPEL, "bankat" adressrum

256K Byte Flash EEPROM
12K Byte RAM
4K Byte EEPROM

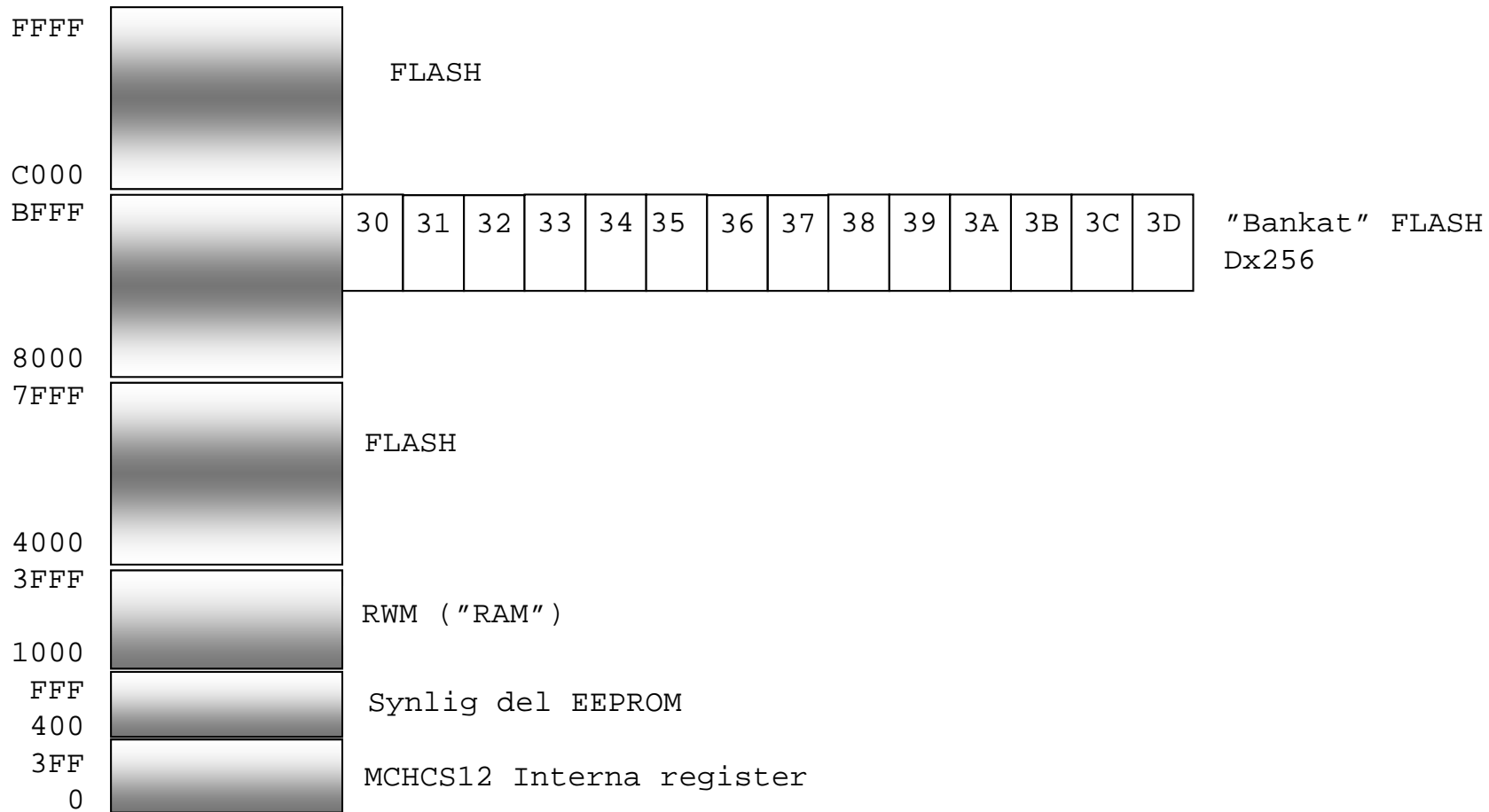

EXEMPEL, i laborationsdator MC12

256K Byte Flash EEPROM
12K Byte RAM
4K Byte EEPROM

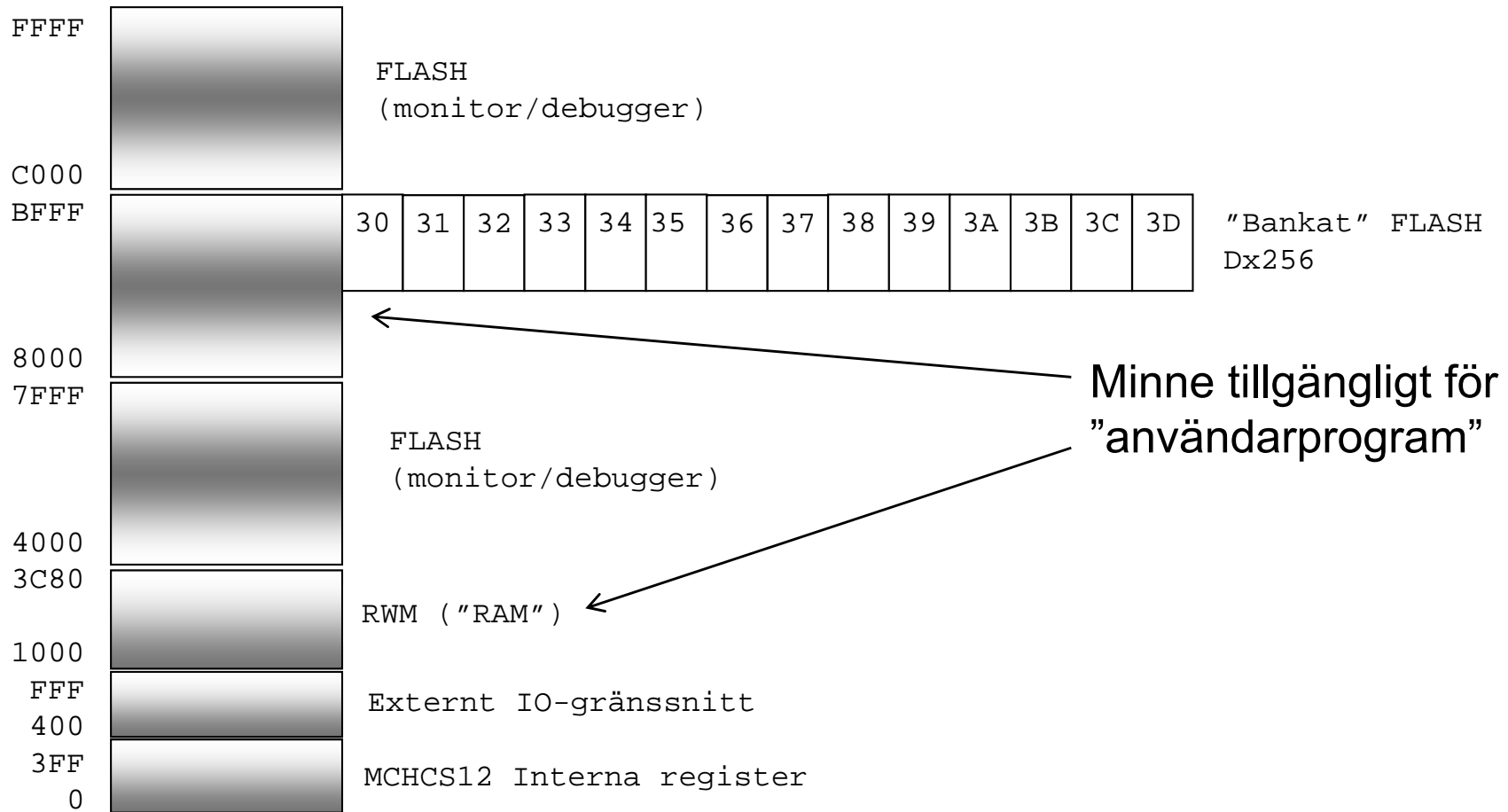

Periferikretsar i HCS12DG256

AD – Analog till Digital omvandling

ECT- Räknarkretsar för noggrann
tidmätning

SCI – Asynkron seriekommunikation

Parallell In-Utmatning

PWM – Pulsbreddsmodulering

Etc...

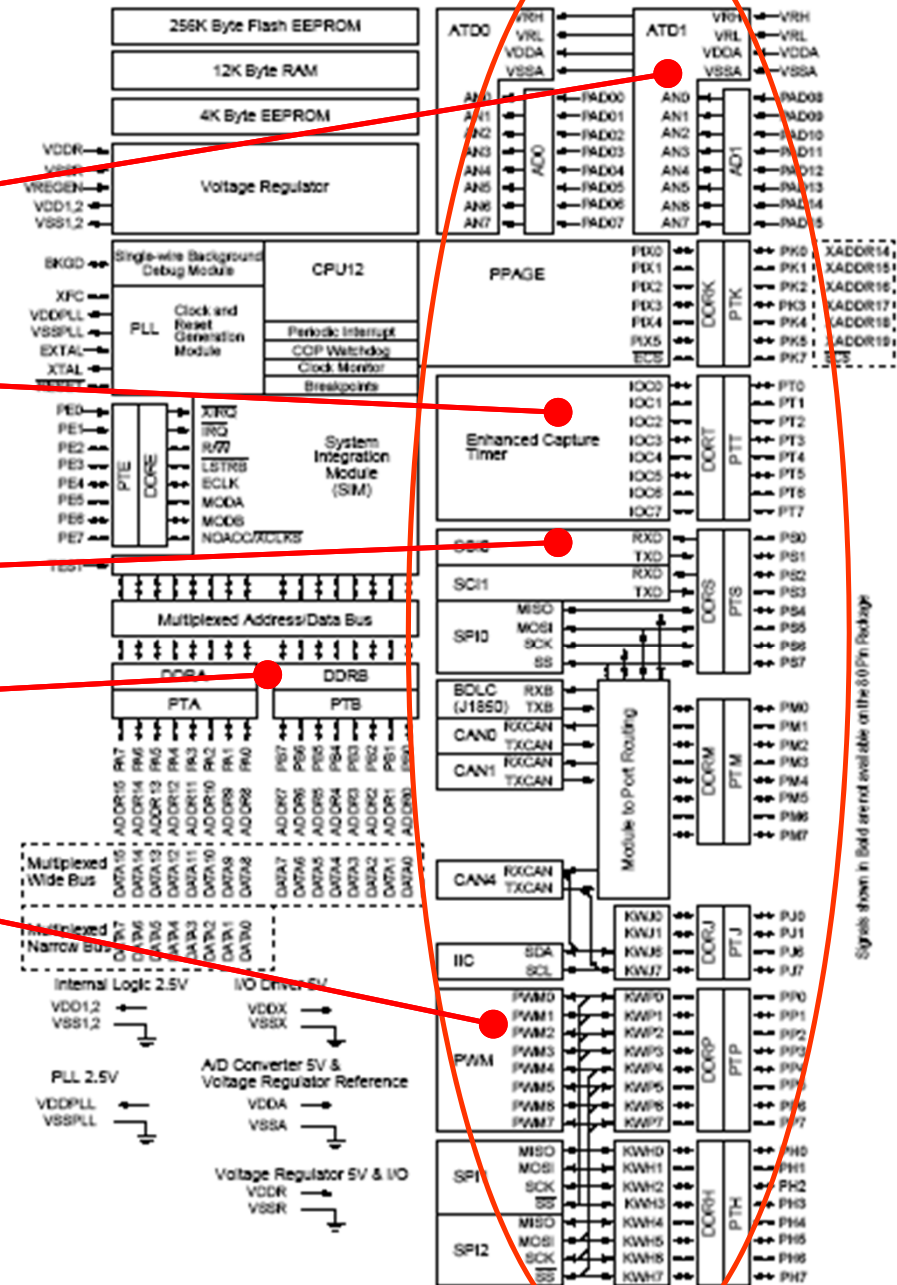

Signals shown in bold are not available on the 60 Pin Package

HCS12DG256, "core"

Centralenhet CPU12

Instruction Set Summary

Source Form	Operation	Addr. Mode	Machine Coding (hex)	Access Detail	S	X	H	I	N	Z	V	C
ABA	(A) + (B) → A Add Accumulators A and B	INH	18 06	00	-	-	-	-	Δ	Δ	Δ	Δ
ABX	(B) + (X) → X Translates to LEAX B,X	IDX	1A E5	02 ¹	-	-	-	-	-	-	-	-
ABY	(B) + (Y) → Y Translates to LEAY B,Y	IDX	19 ED	02 ¹	-	-	-	-	-	-	-	-
ADCA #opr# ADCA opr#A ADCA opr#A ADCA opr#_ysp ADCA opr#_ysp ADCA opr#_ysp ADCA [D_ysp] ADCA [opr#16_ysp]	(A) + (M) + C → A Add with Carry to A	IMM DIR EXT IDX IDX1 IDX2 [D_IDX] [IDX2]	89 11 99 dd 89 bb 11 A9 2b A9 2b ff A9 2b ff A9 2b ff A9 2b ff	0 10P 10P 10P 10P 10P 10P 10P	-	-	-	-	Δ	Δ	Δ	Δ
ADCB #opr# ADCB opr#B ADCB opr#B ADCB opr#_ysp ADCB opr#_ysp ADCB opr#_ysp ADCB [D_ysp] ADCB [opr#16_ysp]	(B) + (M) + C → B Add with Carry to B	IMM DIR EXT IDX IDX1 IDX2 [D_IDX] [IDX2]	C9 11 D9 dd F9 bb 11 E9 2b E9 2b ff E9 2b ff E9 2b ff E9 2b ff	0 10P 10P 10P 10P 10P 10P 10P	-	-	-	-	Δ	Δ	Δ	Δ
ADDA #opr# ADDA opr#A ADDA opr#A ADDA opr#_ysp ADDA opr#_ysp ADDA [D_ysp]	(A) + (M) → A Add without Carry to A	IMM DIR EXT IDX IDX1 IDX2	8B 11 9B dd 8B bb 11 AB 2b AB 2b ff AB 2b ff	0 10P 10P 10P 10P 10P	-	-	-	-	Δ	Δ	Δ	Δ

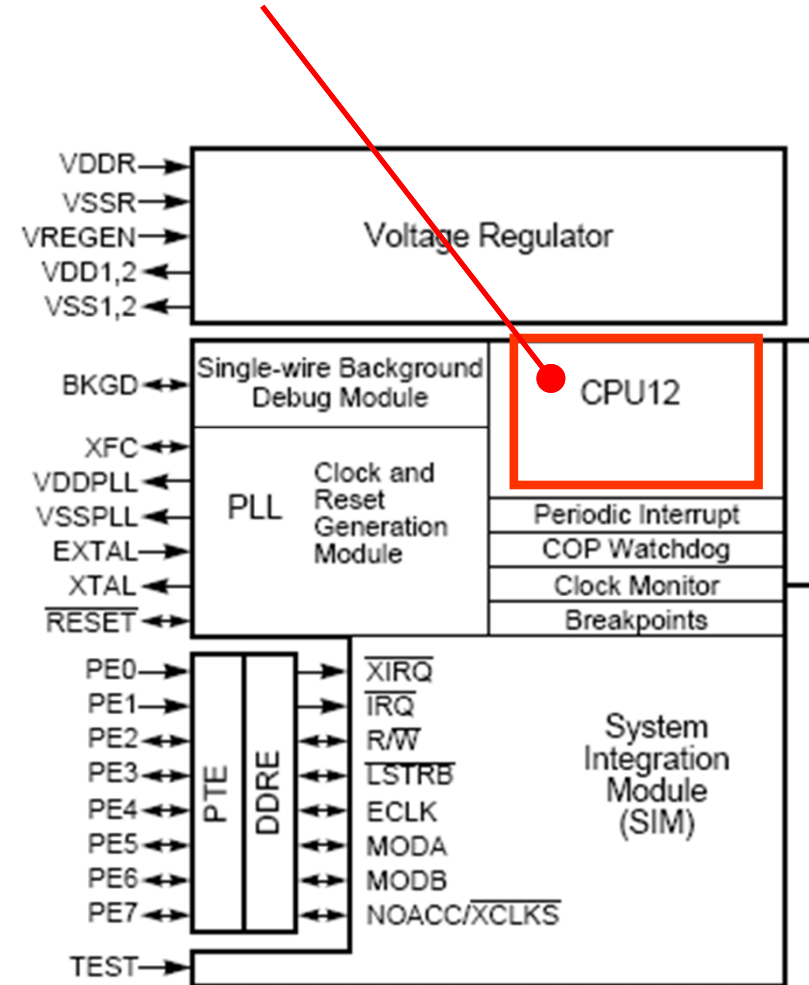

Stack and Memory Layout

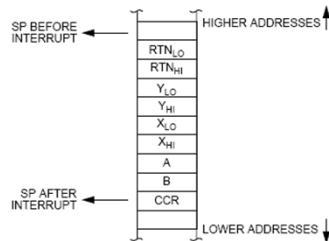

7	A	0	7	B	0	8-BIT ACCUMULATORS A AND B OR 16-BIT DOUBLE ACCUMULATOR D
15				X	0	INDEX REGISTER X
15				Y	0	INDEX REGISTER Y
15				SP	0	STACK POINTER
15				PC	0	PROGRAM COUNTER

Interrupt Vector Locations

\$FFFE, \$FFFF	Power-On (POR) or External Reset
\$FFFC, \$FFFD	Clock Monitor Reset
\$FFFA, \$FFFB	Computer Operating Properly (COP Watchdog Reset)
\$FFF8, \$FFF9	Unimplemented Opcode Trap
\$FFF6, \$FFF7	Software Interrupt Instruction (SWI)
\$FFF4, \$FFF5	XIRQ
\$FFF2, \$FFF3	IRQ
\$FFC0-\$FFF1	Device-Specific Interrupt Sources

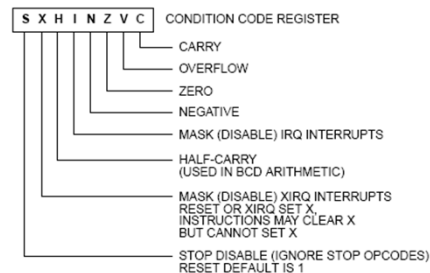

Registeruppsättning CPU12

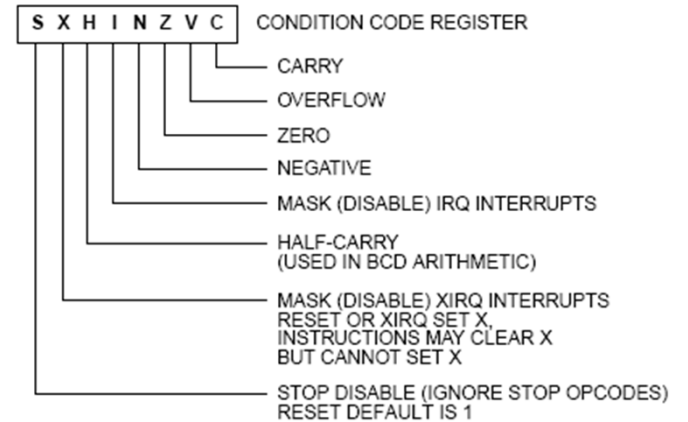
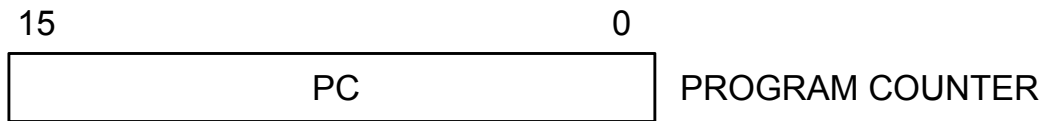
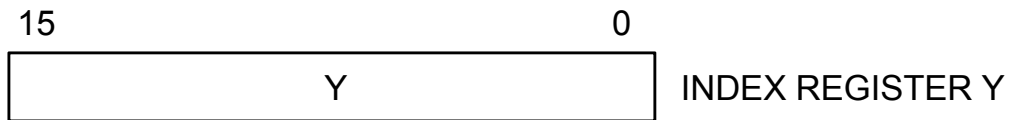
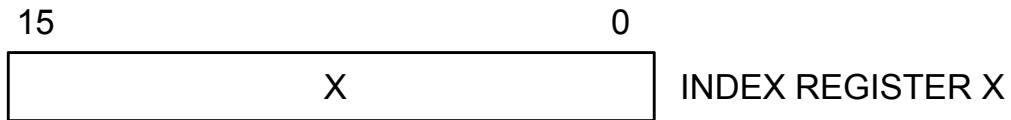
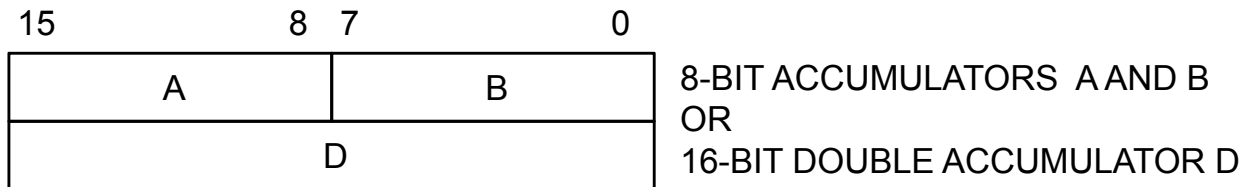

Adresseringsätt

Vi känner igen de flesta adresseringsätten i från FLEX.

Indexerade adresseringsätt kan även användas med register X,Y och SP ibland också med PC (PC-relativt)

Nytt här är också ”Indirekt adressering”

Addressing Mode	Source Format	Abbreviation	Description
Inherent	INST (no externally supplied operands)	INH	Operands (if any) are in CPU registers
Immediate	INST #opr8i or INST #opr16i	IMM	Operand is included in instruction stream 8- or 16-bit size implied by context
Direct	INST opr8a	DIR	Operand is the lower 8-bits of an address in the range \$0000 – \$00FF
Extended	INST opr16a	EXT	Operand is a 16-bit address
Relative	INST rel8 or INST rel16	REL	An 8-bit or 16-bit relative offset from the current pc is supplied in the instruction
Indexed (5-bit offset)	INST oprx5,xysp	IDX	5-bit signed constant offset from x, y, sp, or pc
Indexed (pre-decrement)	INST oprx3,-xys	IDX	Auto pre-decrement x, y, or sp by 1 ~ 8
Indexed (pre-increment)	INST oprx3,+xys	IDX	Auto pre-increment x, y, or sp by 1 ~ 8
Indexed (post-decrement)	INST oprx3,xys-	IDX	Auto post-decrement x, y, or sp by 1 ~ 8
Indexed (post-increment)	INST oprx3,xys+	IDX	Auto post-increment x, y, or sp by 1 ~ 8
Indexed (accumulator offset)	INST abd,xysp	IDX	Indexed with 8-bit (A or B) or 16-bit (D) accumulator offset from x, y, sp, or pc
Indexed (9-bit offset)	INST oprx9,xysp	IDX1	9-bit signed constant offset from x, y, sp, or pc (lower 8-bits of offset in one extension byte)
Indexed (16-bit offset)	INST oprx16,xysp	IDX2	16-bit constant offset from x, y, sp, or pc (16-bit offset in two extension bytes)
Indexed-Indirect (16-bit offset)	INST [opr16,xysp]	[IDX2]	Pointer to operand is found at... 16-bit constant offset from x, y, sp, or pc (16-bit offset in two extension bytes)
Indexed-Indirect (D accumulator offset)	INST [D,xysp]	[D,IDX]	Pointer to operand is found at... x, y, sp, or pc plus the value in D

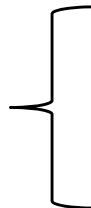

Inherent

Source Form	Operation	Addr. Mode	Machine Coding (hex)	Access Detail	S	X	H	I	N	Z	V	C
CBA	(A) - (B) Compare 8-Bit Accumulators	INH	18 17	∞	-	-	-	-	Δ	Δ	Δ	Δ

Maskinkod för instruktionen

Cykel för cykel beskrivning

Flaggpåverkan

Omedelbar (Immediate) 8-bit/16-bit

LDAA #opr8i	(M) ⇒ A	IMM	86 11	P	-	-	-	-	Δ	Δ	0	-
LDAA opr8a	Load Accumulator A	DIR	96 dd	rFP								
LDAA opr16a		EXT	B6 hh 11	rOP								
LDAA oprx0_xysp		IDX	A6 xb	rFP								
LDAA oprx9_xysp		IDX1	A6 xb ff	rPO								
LDAA oprx16_xysp		IDX2	A6 xb ee ff	frPP								
LDAA [D,xysp]		[D,IDX]	A6 xb	fIfrFP								
LDAA [opr16.xysp]		[IDX2]	A6 xb ee ff	fIDrFP								
LDD #opr16i	(M:M+1) ⇒ A:B	IMM	CC jj kk	OP	-	-	-	-	Δ	Δ	0	-
LDD opr8a	Load Double Accumulator D (A:B)	DIR	DC dd	rFP								
LDD opr16a		EXT	FC hh 11	rOP								
LDD oprx0_xysp		IDX	EC xb	rFP								
LDD oprx9_xysp		IDX1	EC xb ff	rPO								
LDD oprx16_xysp		IDX2	EC xb ee ff	frPP								
LDD [D,xysp]		[D,IDX]	EC xb	fIfrFP								
LDD [opr16,xysp]		[IDX2]	EC xb ee ff	fIPrFP								

opr8i, 8-bitars konstant om 8-bitars register

Opr16i, 16-bitars konstant om 16-bitars register

Direkt (Direct Page)

Absolut (Extended)

LDAA #opr8i	(M) ⇒ A Load Accumulator A	IMM	86 11	P	-	-	-	-	Δ	Δ	0	-
LDAA opr8a		DIR	96 dd	rFP								
LDAA opr16a		EXT	B6 hh ll	rOP								
LDAA oprx0_xysp		IDX	A6 xb	rFP								
LDAA oprx9_xysp		IDX1	A6 xb ff	rPO								
LDAA oprx16_xysp		IDX2	A6 xb ee ff	frPP								
LDAA [D,xysp]		[D,IDX]	A6 xb	fIfrFP								
LDAA [opr16.xysp]		[IDX2]	A6 xb ee ff	fIDrFD								
LDD #opr16i	(M:M+1) ⇒ A:B Load Double Accumulator D (A:B)	IMM	CC jj kk	OP	-	-	-	-	Δ	Δ	0	-
LDD opr8a		DIR	DC dd	rFP								
LDD opr16a		EXT	FC hh ll	rOP								
LDD oprx0_xysp		IDX	EC xb	rFP								
LDD oprx9_xysp		IDX1	EC xb ff	rPO								
LDD oprx16_xysp		IDX2	EC xb ee ff	frPP								
LDD [D,xysp]		[D,IDX]	EC xb	fIfrFP								
LDD [opr16,xysp]		[IDX2]	EC xb ee ff	fIPrFP								

opr16a, kan adressera hela adressintervallet 0000-FFFF

opr8a, kan enbart adressera intervallet 0000-00FF, anger minst signifikant byte av adressen

PC-relativ ("BRANCH"-instruktioner)

- ❑ 8-bitars offset (-128..127)
- ❑ 9-bitars offset (-256..255)
- ❑ 16-bitars offset (-32768..32767)

<i>BRA rel8</i>	Branch Always (if 1 = 1)	REL	20 rr
<i>IBEQ abdxys, rel9</i>	$(cntr) + 1 \Rightarrow cntr$ If $(cntr) = 0$, then Branch else Continue to next instruction Increment Counter and Branch if = 0 (cntr = A, B, D, X, Y, or SP)	REL (9-bit)	04 1b rr
<i>IBNE abdxys, rel9</i>	$(cntr) + 1 \Rightarrow cntr$ if $(cntr) \neq 0$, then Branch; else Continue to next instruction Increment Counter and Branch if $\neq 0$ (cntr = A, B, D, X, Y, or SP)	REL (9-bit)	04 1b rr
<i>LBCC rel16</i>	Long Branch if Carry Clear (if C = 0)	REL	18 24 qq rr

Indexerade adresserings sätt:

- Register relativ, konstant offset

LDAA #opr8i	(M) ⇒ A
LDAA opr8a	Load Accumulator A
LDAA opr16a	
LDAA opr0_xysp	
LDAA opr9_xysp	
LDAA opr16_xysp	
LDAA [D, xysp]	
LDAA [opr16.xysp]	

opr0_xysp	Indexed addressing postbyte code:
	opr3,-xys Predecrement X or Y or SP by 1 . . . 8
	opr3,+xys Preincrement X or Y or SP by 1 . . . 8
	opr3,xys- Postdecrement X or Y or SP by 1 . . . 8
	opr3,xys+ Postincrement X or Y or SP by 1 . . . 8
	opr5,xysp 5-bit constant offset from X or Y or SP or PC
	abd,xysp Accumulator A or B or D offset from X or Y or SP or PC
opr3	— Any positive integer 1 . . . 8 for pre/post increment/decrement
opr5	— Any value in the range -16 . . . +15
opr9	— Any value in the range -256 . . . +255
opr16	— Any value in the range -32,768 . . . 65,535

Basregister kan vara något av: X,Y,SP,PC

EXEMPEL:

```
LDAA    5 , X
STAA    20 , Y
LDAA    sym , PC
STA     off , SP
. . .
```

Specialfall: n , PCR

```
LDAA    sym , PCR
```

Antag PC pekar på nästa instruktion.

Operanden är här PC-sym, jfr offsetberäkning för "BRA"-instruktioner

Observera, ingen syntaktisk skillnad.
Assemblator väljer effektivast kodning

Indexerade adresseringssätt:

- ❑ Auto pre- increment/decrement
- ❑ Auto post- increment/decrement

LDAA #opr8i	(M) ⇒ A	<i>opr0_xysp</i> — Indexed addressing postbyte code:
LDAA opr8a	Load Accumulator A	<i>opr3,-xys</i> Predecrement X or Y or SP by 1 . . . 8
LDAA opr16a		<i>opr3,+xys</i> Preincrement X or Y or SP by 1 . . . 8
LDAA <i>opr0_xysp</i>		<i>opr3,xys-</i> Postdecrement X or Y or SP by 1 . . . 8
LDAA <i>opr9,xysp</i>		<i>opr3,xys+</i> Postincrement X or Y or SP by 1 . . . 8
LDAA <i>opr16,xysp</i>		<i>opr5,xysp</i> 5-bit constant offset from X or Y or SP or PC
LDAA [D, <i>xysp</i>]		<i>abd,xysp</i> Accumulator A or B or D offset from X or Y or SP or PC
LDAA [<i>opr16.xysp</i>]		<i>opr3</i> — Any positive integer 1 . . . 8 for pre/post increment/decrement
		<i>opr5</i> — Any value in the range -16 . . . +15
		<i>opr9</i> — Any value in the range -256 . . . +255
		<i>opr16</i> — Any value in the range -32,768 . . . 65,535

Basregister kan vara något av: X,Y,SP

EXEMPEL:

```
LDAA    1 , -X
STAA    4 , Y-
STAB    8 , +SP
LDAB    7 , SP+
. . .
```

Indexerade adresseringssätt:

- Register relativ, offset i ackumulator

LDAA #opr8i	(M) ⇒ A	<i>opr0_xysp</i> — Indexed addressing postbyte code:
LDAA opr8a	Load Accumulator A	
LDAA opr16a		
LDAA opr0_xysp		
LDAA opr9,xysp		
LDAA opr16,xysp		
LDAA [D,xysp]		
LDAA [opr16.xvso]		

<i>opr3,-xys</i>	Predecrement X or Y or SP by 1 . . . 8
<i>opr3,+xys</i>	Preincrement X or Y or SP by 1 . . . 8
<i>opr3,xys-</i>	Postdecrement X or Y or SP by 1 . . . 8
<i>opr3,xys+</i>	Postincrement X or Y or SP by 1 . . . 8
<i>opr5,xysp</i>	5-bit constant offset from X or Y or SP or PC
<i>abd,xysp</i>	Accumulator A or B or D offset from X or Y or SP or PC

<i>opr3</i>	— Any positive integer 1 . . . 8 for pre/post increment/decrement
<i>opr5</i>	— Any value in the range -16 . . . +15
<i>opr9</i>	— Any value in the range -256 . . . +255
<i>opr16</i>	— Any value in the range -32,768 . . . 65,535

Basregister kan vara något av: X,Y,SP,PC

EXEMPEL:

```
LDAA    A , X
STAA    B , Y
STAB    D , SP
LDAB    D , PC
. . .
```

Indexerade adresseringsätt:

□ Indirekt

LDAA #opr8i	(M) ⇒ A
LDAA opr8a	Load Accumulator A
LDAA opr16a	
LDAA oprx0_xysp	
LDAA oprx9_xysp	
LDAA oprx16_xysp	
LDAA [D, xysp]	
LDAA [opr16.xysp]	

oprx0_xysp — Indexed addressing postbyte code:

- opr3,-xys* Predecrement X or Y or SP by 1 . . . 8
- opr3,+xys* Preincrement X or Y or SP by 1 . . . 8
- opr3,xys-* Postdecrement X or Y or SP by 1 . . . 8
- opr3,xys+* Postincrement X or Y or SP by 1 . . . 8
- opr5,xysp* 5-bit constant offset from X or Y or SP or PC
- abd,xysp* Accumulator A or B or D offset from X or Y or SP or PC

opr3 — Any positive integer 1 . . . 8 for pre/post increment/decrement

opr5 — Any value in the range -16 . . . +15

opr9 — Any value in the range -256 . . . +255

opr16 — Any value in the range -32,768 . . . 65,535

EXEMPEL:

```
LDAA [D, X]
STAA [sym, PCR]
STAB [2, SP]
LDAB [D, Y]
...
```

Instruktionsgrupper

LOAD-instruktioner

Mnemonic	Funktion	Operation
LDA	Load A	$(M) \rightarrow A$
LDAB	Load B	$(M) \rightarrow B$
LDD	Load D	$(M:M+1)_1 \rightarrow A:B$
LDS	Load SP	$(M:M+1)_1 \rightarrow SP_H:SP_L$
LDX	Load index register X	$(M:M+1)_1 \rightarrow X_H:X_L$
LDY	Load index register Y	$(M:M+1)_1 \rightarrow Y_H:Y_L$
LEAS	Load effective address into SP	Effective address \rightarrow SP
LEAX	Load effective address into X	Effective address \rightarrow X
LEAY	Load effective address into Y	Effective address \rightarrow Y

STORE-instruktioner

Mnemonic	Funktion	Operation
STAA	Store A	$(A) \rightarrow M$
STAB	Store B	$(B) \rightarrow M$
STD	Store D	$(A) \rightarrow M, (B) \rightarrow M+1$
STS	Store SP	$SP_H:SP_L \rightarrow M:M+1$
STX	Store X	$X_H:X_L \rightarrow M:M+1$
STY	Store Y	$Y_H:Y_L \rightarrow M:M+1$

MOVE-instruktioner

Mnemonic	Funktion	Operation
MOVB	Move byte (8 bitar)	$(M_1) \rightarrow M_2$
MOVW	Move word (8 bitar)	$(M:M+1)_1 \rightarrow M:M+1_2$

EXEMPEL: Kopiera *byte*

```

LDAB  $3000
STAB  $3001
eller
LDA   $3000
STAA  $3001
eller
MOVB  $3000, $3001
    
```

EXEMPEL: Kopiera *word*

```

LDD   $3000
STD   $3001
eller
LDX   $3000
STX   $3001
eller
LDY   $3000
STY   $3001
eller
MOVW  $3000, $3001
    
```

Instruktioner för kopiering av registerinnehåll

Mnemonic	Funktion	Operation
TAB	Transfer A to B anm: Ekv. Med TFR A, B	(A)→B
TAP	Transfer A to CCR anm: Ekv. Med TFR A, CCR	(A)→CCR
TBA	Transfer B to A	(B)→A
TFR	Transfer register to register	(A,B,CCR,D,X,Y eller SP) → (A,B,CCR,D,X,Y eller SP)
TPA	Transfer CCR to A anm: Ekv. Med TFR CCR, A	(CCR)→A
TSX	Transfer SP to X anm: Ekv. Med TFR SP, X	(SP)→X
TSY	Transfer SP to Y anm: Ekv. Med TFR SP, Y	(SP)→Y
TXS	Transfer X to SP anm: Ekv. Med TFR X, SP	(X)→SP
TYS	Transfer Y to SP anm: Ekv. Med TFR Y, SP	(Y)→SP

← Använd denna

Övriga finns här av
"kompatibilitetsskäl"

Instruktioner för växling av registerinnehåll

Mnemonic	Funktion	Operation
EXG	Exchange register to register	(A,B,CCR,D,X,Y eller SP) ↔ (A,B,CCR,D,X,Y eller SP)
XGDX	Exchange D with X anm: Ekv. Med EXG D, X - EXG X, D	(D) ↔ (X)
XGDY	Exchange D with Y anm: Ekv. Med EXG D, Y - EXG Y, D	(D) ↔ (Y)

← Använd denna

Övriga finns här av
"kompatibilitetsskäl"

Instruktion för teckenutvidgning

Mnemonic	Funktion	Operation
SEX	Teckenutvidga 8 bitars operand	(A,B,CCR) → (D,X,Y eller SP)

Ovillkorlig programflödeskontroll

Mnemonic	Funktion	Operation
BSR	Anrop av subrutin. PC-relativ operand	$SP-2 \Rightarrow SP$ $RetAdrL:RetAdrH \Rightarrow$ $M_{(SP)}:M_{(SP+1)}$ $Adress \Rightarrow PC$
BRA	“Hopp” till adress. PC-relativ operand	$Adress \Rightarrow PC$
CALL	Anrop av subrutin Absolut operand (20 bitar) Anm: Användes vid programflödesändring mellan olika minnesbankar (\$8000- \$BFFF)	$SP-2 \Rightarrow SP$ $RetAdrL:RetAdrH \Rightarrow$ $M_{(SP)}:M_{(SP+1)}$ $Subrutinadress \Rightarrow PC$ $SP-1 \Rightarrow SP$ $(PPAGE) \Rightarrow M_{(SP)}$ $PAGE \Rightarrow PPAGE$ $Subrutinadress \Rightarrow PC$
JMP	“Hopp” till adress. Absolut operand	$Subrutinadress \Rightarrow PC$
JSR	Anrop av subrutin Absolut operand	$SP-2 \Rightarrow SP$ $RetAdrL:RetAdrH \Rightarrow$ $M_{(SP)}:M_{(SP+1)}$ $Subrutinadress \Rightarrow PC$
RTC	Återvänd från subrutin. Returadress från STACK och PPAGE	$M_{(SP)} \Rightarrow (PPAGE)$ $SP+1 \Rightarrow SP$ $M_{(SP)}:M_{(SP+1)} \Rightarrow PC_H:PC_L$ $SP+2 \Rightarrow SP$
RTS	Återvänd från subrutin. Returadress från STACK	$M_{(SP)}:M_{(SP+1)} \Rightarrow PC_H:PC_L$ $SP+2 \Rightarrow SP$

Instruktioner för addition

Mnemonic	Funktion	Operation
ABA	Addera B till A	$(A)+(B) \rightarrow A$
ABX	Addera B till X anm: Ekv. med LEAX B, X	$(X)+(B) \rightarrow X$
ABY	Addera B till Y anm: Ekv. med LEAY B, Y	$(Y)+(B) \rightarrow Y$
ADCA	Addition med carry till A	$(A)+(M)+C \rightarrow A$
ADCB	Addition med carry till B	$(B)+(M)+C \rightarrow B$
ADDA	Addition till A	$(A)+(M) \rightarrow A$
ADDB	Addition till B	$(B)+(M) \rightarrow B$
ADDD	Addition till D (A:B)	$(D)+(M:M+1) \rightarrow D$

Mnemonic	Funktion	Operation
INC	Incrementera i minnet	$(M)+\$01 \rightarrow M$
INCA	Inkrementera A	$(A)+\$01 \rightarrow A$
INCB	Inkrementera B	$(B)+\$01 \rightarrow B$
INS	Inkrementera SP anm: Ekv. med LEAS 1, SP	$(SP)+\$0001 \rightarrow SP$
INX	Inkrementera X anm: Ekv. med LEAX 1, X	$(X)+\$0001 \rightarrow X$
INY	Inkrementera Y anm: Ekv. med LEAY 1, Y	$(Y)+\$0001 \rightarrow Y$

Instruktioner för subtraktion

Mnemonic	Funktion	Operation
SBA	Subtrahera B från A	$(A)-(B) \rightarrow A$
SBCA	Subtrahera med borrow från A	$(A)-(M)-C \rightarrow A$
SBCB	Subtrahera med borrow från B	$(B)-(M)-C \rightarrow B$
SUBA	Subtrahera från A	$(A)-(M) \rightarrow A$
SUBB	Subtrahera från B	$(B)-(M) \rightarrow B$
SUBD	Subtrahera från D (A:B)	$(D)-(M:M+1) \rightarrow D$

Mnemonic	Funktion	Operation
DEC	Dekrementera i minnet	$(M)-\$01 \rightarrow M$
DECA	Dekrementera A	$(A)-\$01 \rightarrow A$
DECB	Dekrementera B	$(B)-\$01 \rightarrow B$
DES	Dekrementera SP anm: Ekv. med LEAS -1, SP	$(SP)-\$0001 \rightarrow SP$
DEX	Dekrementera X anm: Ekv. med LEAX -1, X	$(X)-\$0001 \rightarrow X$
DEY	Dekrementera Y anm: Ekv. med LEAY -1, Y	$(Y)-\$0001 \rightarrow Y$

Instruktioner för logikoperationer

Mnemonic	Funktion	Operation
ANDA	Bitvis "och" A med minnesinnehåll	$(A) \bullet (M) \Rightarrow A$
ANDB	Bitvis "och" A med minnesinnehåll	$(B) \bullet (M) \Rightarrow B$
ANDCC	Bitvis "och" CC med minnesinnehåll	$(CCR) \bullet (M) \Rightarrow CCR$
EORA	Bitvis "exklusivt eller" A med minnesinnehåll	$(A) \oplus (M) \Rightarrow A$
EORB	Bitvis "exklusivt eller" B med minnesinnehåll	$(B) \oplus (M) \Rightarrow B$
ORAA	Bitvis "eller" A med minnesinnehåll	$(A) + (M) \Rightarrow A$
ORAB	Bitvis "eller" B med minnesinnehåll	$(B) + (M) \Rightarrow B$
ORCC	Bitvis "eller" CCR med minnesinnehåll	$(CCR) + (M) \Rightarrow CCR$

EXEMPEL: Nollställ bit 7-bit 4 på adress \$3000

```
LDAB    $3000
ANDB    #%00001111
STAB    $3000
```

EXEMPEL: Ettställ bit 7 och bit 0 på adress \$3000

```
LDAB    $3000
ORAB    #%10000001
STAB    $3000
```

Unära operationer

Mnemonic	Funktion	Operation
CLC	Nollställ carryflaggan i CCR	$0 \Rightarrow C$
CLI	Nollställ avbrottsmask i CCR	$0 \Rightarrow I$
CLR	Nollställ minnesinnehåll	$\$00 \Rightarrow M$
CLRA	Nollställ A	$\$00 \Rightarrow A$
CLRB	Nollställ B	$\$00 \Rightarrow B$
CLV	Nollställ overflowflaggan i CCR	$0 \Rightarrow V$
COM	Ettkomplementera minnesinnehåll	$\$FF-(M) \Rightarrow M$
COMA	Ettkomplementera A	$\$FF-(A) \Rightarrow A$
COMB	Ettkomplementera B	$\$FF-(B) \Rightarrow A$
NEG	Tvåkomplementera minnesinnehåll	$\$00-(M) \Rightarrow M$
NEGA	Tvåkomplementera A	$\$00-(A) \Rightarrow A$
NEGB	Tvåkomplementera B	$\$00-(B) \Rightarrow B$

EXEMPEL: Invertera bit 2 och bit 1 på adress \$3000

```
LDAB    $3000
EORB    #%00000110
STAB    $3000
```

Logiska skiftoperationer

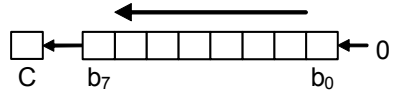
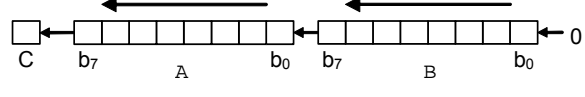
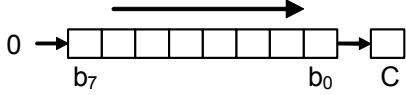
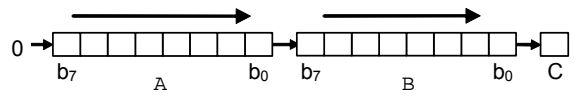
Mnemonic	Funktion	Operation
LSL	Logiskt vänsterskift i minnet	
LSLA	Logiskt vänsterskift A	
LSLB	Logiskt vänsterskift B	
LSLD	Logiskt vänsterskift D	
LSR	Logiskt högerskift i minnet	
LSRA	Logiskt högerskift A	
LSRB	Logiskt högerskift B	
LSRD	Logiskt högerskift D	

Exempel på användning:

Multiplikation med 2, tal utan tecken.

Division med 2, tal utan tecken.

Aritmetiska skiftoperationer

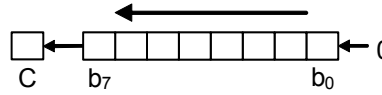
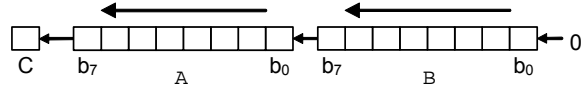
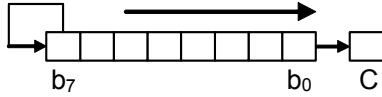
Mnemonic	Funktion	Operation
ASL	Aritmetiskt vänsterskift i minnet (ekv. med LSL)	
ASLA	Aritmetiskt vänsterskift A (ekv. med LSLA)	
ASLB	Aritmetiskt vänsterskift B (ekv. med LSLB)	
ASLD	Aritmetiskt vänsterskift D (ekv. med LSLD)	
ASR	Aritmetiskt högerskift i minnet	
ASRA	Aritmetiskt högerskift A	
ASRB	Aritmetiskt högerskift B	

Exempel på användning, högerskift:
Division med 2, tal med tecken.

Instruktioner för rotation (carry-skift)

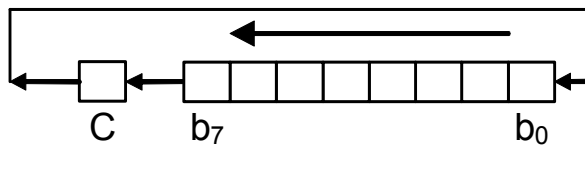
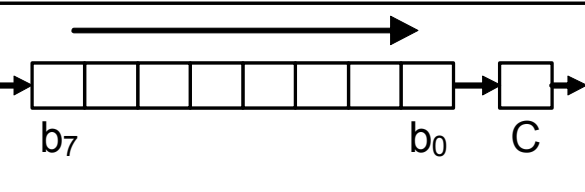
Mnemonic	Funktion	Operation
ROL	Rotation vänster via carry i minnet	
ROLA	Rotation vänster via carry A	
ROLB	Rotation vänster via carry B	
ROR	Rotation höger via carry i minnet	
RORA	Rotation höger via carry A	
RORB	Rotation höger via carry B	

EXEMPEL: Skifta ett 32-bitars tal på adress \$3000, 1 steg åt höger

```

LSR $3000
ROR $3001
ROR $3002
ROR $3003
  
```

Exempel på användning:

Skiftoperationer på tal större än 8 bitar.

Instruktioner för jämförelser och test

Mnemonic	Funktion	Operation
CBA	Jämför B med A	(A)-(B)
CMPA	Jämför A med minne	(A)-(M)
CMPB	Jämför B med minne	(B)-(M)
CPD	Jämför D med minne	(A:B)-(M:M+1)
CPS	Jämför SP med minne	(SP)-(M:M+1)
CPX	Jämför X med minne	(X)-(M:M+1)
CPY	Jämför Y med minne	(Y)-(M:M+1)

JÄMFÖRELSE

Två operander
BINÄR operation

Mnemonic	Funktion	Operation
TST	Testa minnesinnehåll	(M)-\$00
TSTA	Testa register A	(A)-\$00
TSTB	Testa register B	(B)-\$00

TEST

En operand
UNÄR operation

Villkorlig programflödeskontroll

Mnemonic	Funktion	Villkor
Enkla flaggtest		
BCS	“Hopp” om <i>carry</i>	C=1
BCC	“Hopp” om ICKE <i>carry</i>	C=0
BEQ	“Hopp” om <i>zero</i>	Z=1
BNE	“Hopp” om ICKE <i>zero</i>	Z=0
BMI	“Hopp” om <i>negative</i>	N=1
BPL	“Hopp” om ICKE <i>negative</i>	N=0
BVS	“Hopp” om <i>overflow</i>	V=1
BVC	“Hopp” om ICKE <i>overflow</i>	V=0
Test av tal utan tecken		
BHI	Villkor: R>M	$C + Z = 0$
BHS	Villkor: R≥M	C=0
BLO	Villkor: R<M	C=1
BLS	Villkor: R≤M	$C + Z = 1$
Test av tal med tecken		
BGT	Villkor: R>M	$Z + (N \oplus V) = 0$
BGE	Villkor: R≥M	$N \oplus V = 0$
BLT	Villkor: R<M	$N \oplus V = 1$
BLE	Villkor: R≤M	$Z + (N \oplus V) = 1$

Används typiskt tillsammans med jämförelse/test instruktioner.

EXEMPEL

```
LDAB    $3000
CMPB  $3001
BEQ   L1
... ..
```

Instruktioner för räknande programslingor

Mnemonic	Funktion	Villkor
DBEQ	Dekrementera innehåll i register. "Hoppa" om resultatet = 0. (register: A,B,D,X,Y,SP)	(register) - 1 ⇒ register om(register)=0; "hoppa"; annars: nästa instruktion
DBNE	Dekrementera innehåll i register. "Hoppa" om resultatet ≠ 0. (register: A,B,D,X,Y,SP)	(register) - 1 ⇒ register om(register)≠0; "hoppa"; annars: nästa instruktion
IBEQ	Inkrementera innehåll i register. "Hoppa" om resultatet = 0. (register: A,B,D,X,Y,SP)	(register) + 1 ⇒ register om(register)=0; "hoppa"; annars: nästa instruktion
IBNE	Inkrementera innehåll i register. "Hoppa" om resultatet ≠ 0. (register: A,B,D,X,Y,SP)	(register) + 1 ⇒ register om(register)≠0; "hoppa"; annars: nästa instruktion
TBEQ	Testa innehåll i register. "Hoppa" om resultatet = 0. (register: A,B,D,X,Y,SP)	om(register)=0; "hoppa"; annars: nästa instruktion
TBNE	Testa innehåll i register. "Hoppa" om resultatet ≠ 0. (register: A,B,D,X,Y,SP)	om(register)≠0; "hoppa"; annars: nästa instruktion

Sammansatta instruktioner.

EXEMPEL

DBEQ B, L2

samma sak som

DECB

BEQ L2